



P U M P S

Pump'n Hard Iron

INSTALLATION, OPERATION AND MAINTENANCE MANUAL POLARIS - SERIES TBM 200 LH (8") - TYPE PHO / PBO / PVO			1 of 29
DOCUMENT NBR. : PED-010	REVISION: 1	EFFECTIVE DATE:	08-24-2004

POLARIS SERIES TBM 200 LH (8") TYPE PHO / PBO / PVO
ELECTRO-SUBMERSIBLE PUMP

PUMP TYPE: TBM 200 LH (8") TYPE ()

POLARIS PART NBR.: 700.200.05.

HP / V / Hz / Poles: / / /

INSULATION: F H SUPER H

EXPLOSION PROOF: Y N

EQUIPMENT OPTIONS:

POWER CABLE: ADDITIONAL (FEET)

VITON MOTOR O-RINGS

VITON SEAL ELASTOMERS

"SEAL GUARD"

"SLURRY BOSS"

"MOTOR SENTRY"

SS MOTOR FLANGE

COAL TAR EPOXY

PUMP SERIAL NUMBER: _____

DATE: _____

CUSTOMER: _____

CUSTOMER P.O. NBR. _____

SHIPPED TO: _____



INSTALLATION, OPERATION AND MAINTENANCE MANUAL POLARIS - SERIES TBM 200 LH (8") - TYPE PHO / PBO / PVO			2 of 29
DOCUMENT NBR. :	PED-010	REVISION:	1
		EFFECTIVE DATE:	08-24-2004

TABLE OF CONTENTS

SECTION 1.0 INTRODUCTION

SECTION 2.0 WARRANTIES

SECTION 3.0 SAFETY

SECTION 4.0 MECHANICAL INSTALLATION

4.1 RECEIVING INSPECTION

4.2 STORAGE

4.2.1 NEW PUMP AND EQUIPMENT STORAGE

4.2.2 USED PUMP STORAGE

4.2.3 SPARE PARTS STORAGE

4.3 HANDLING

4.4 MECHANICAL SEAL INSPECTION

4.5 PUMP SET UP / MOUNTING

4.5.1 CABLE AND CHAIN SUSPENSION

4.5.2 OPTIONAL LIFTING / SUSPENSION BAIL MOUNTING

4.5.3 FLOOR MOUNTING

4.6 PIPING

4.6.1 DISCHARGE PIPING / DISCHARGE HOSE

4.6.2 PRIMARY SEAL FLUSH PIPING

4.6.3 OPTIONAL WATER JACKET / PIPING

4.6.4 OPTIONAL WATER JET RING

SECTION 5.0 ELECTRICAL INSTALLATION

5.1 GENERAL

5.2 MOISTURE DETECTION RELAY - THERMAL PROTECTION

5.3 INSTALLATION

**REFER TO THE RELIANCE ELECTRIC MOTOR
 INSTALLATION & MAINTENANCE MANUAL FOR
 DUTY MASTER® SUBMERSIBLE MOTORS (SECTION 8.2)**



INSTALLATION, OPERATION AND MAINTENANCE MANUAL POLARIS - SERIES TBM 200 LH (8") - TYPE PHO / PBO / PVO			3 of 29
DOCUMENT NBR. : PED-010	REVISION: 1	EFFECTIVE DATE:	08-24-2004

SECTION 6.0 OPERATION

- 6.1 PRE START UP CHECK**
- 6.2 PUMP START UP**
- 6.3 PUMP SHUT DOWN**
- 6.4 TROUBLE SHOOTING**

SECTION 7.0 WET END INSTALLATION

- 7.1 TBM 200 LH - Type PHO - Open Suction, Strainer**
- 7.2 TBM 200 LH - Type PBO - Open Suction, Strainer, Solids Mixer Attachment**
- 7.3 TBM 200 LH - Type PVO - Open Suction, Strainer, Shredder Attachment**

SECTION 8.0 APPENDIX

- 8.1 PUMP GENERAL ARRANGEMENT DRAWING, TBM 200 LH – PHO / PBO / PVO**
 - 8.1.1 PUMP PERFORMANCE CURVE TYPE - PHO**
 - 8.1.2 PUMP PERFORMANCE CURVE TYPE - PBO**
 - 8.1.3 PUMP PERFORMANCE CURVE TYPE - PVO**
- 8.2 RELIANCE ELECTRIC MOTOR
INSTALLATION & MAINTENANCE MANUAL FOR
DUTY MASTER® SUBMERSIBLE MOTORS**
- 8.3 MOISTURE DETECTION RELAY**
- 8.4 IMPELLER INSTALLATION / BOLT TORQUE REQUIREMENTS**



INSTALLATION, OPERATION AND MAINTENANCE MANUAL POLARIS - SERIES TBM 200 LH (8") - TYPE PHO / PBO / PVO			4 of 29
DOCUMENT NBR. : PED-010	REVISION: 1	EFFECTIVE DATE:	08-24-2004

1.0 INTRODUCTION

Your new **Series TBM** pump has been designed and manufactured to perform for many years with a minimum of maintenance. However, parts will wear and need replacing eventually. The period between maintenance will greatly depend on the service and your maintenance program.

Series TBM pumps are heavy-duty Electro-submersible pumps featuring motor armatures with a nominal service factor up to 2 depending on pump wet end and motor combination.

Pumps with standard motors are designed to operate completely submersed in liquids with pH values from 6–14 and temperatures not exceeding 40°C (104°F). Higher temperatures and / or dry-running applications will require H or Super H insulation and / or an optional water jacket.

**Motor modules of series TBM can be ordered in standard configuration
or as explosion proof units per
Class 1, Groups C&D, Temperature code T3C**

**UL Listed, File No. E10822
CSA Certified, File No. LR19467-15 (Frames 140,180,210,250 & 360)
CSA Certified, File No. LR19467-15 (Frame 320)**

This manual has been compiled to help you minimize your maintenance and speed repairs when required. Read and understand this manual.

Please provide the Serial Number of your equipment if additional manuals are needed.

WHEN ORDERING PARTS ALWAYS REFER TO PUMP SERIAL NUMBER.
THIS NUMBER IS FOUND ON THE NAMEPLATE ON THE PUMP.



INSTALLATION, OPERATION AND MAINTENANCE MANUAL			5 of 29
POLARIS - SERIES TBM 200 LH (8") - TYPE PHO / PBO / PVO			
DOCUMENT NBR. : PED-010	REVISION: 1	EFFECTIVE DATE:	08-24-2004

2.0 WARRANTIES

Seller warrants that the products covered by this contract conform to applicable drawings and specifications accepted in writing by Seller, will be free from defects in material and workmanship, will be merchantable and will perform in accordance with the detailed specifications accepted in writing by Seller.

These warranties extend for a period of twelve (12) months from the date of purchase by Buyer. Buyer's exclusive remedy and Seller's sole duty under these warranties is to repair or replace the product. Normal wear and tear on Seller's product shall not constitute a warranty defect.

THERE ARE NO OTHER WARRANTIES, EXPRESS OR IMPLIED, WHICH EXTEND BEYOND THOSE SET FORTH ABOVE. THE WARRANTY OF MERCHANTABILITY IS LIMITED TO THE PERIOD SPECIFIED ABOVE.

These warranties are contingent upon the product being stored, installed, maintained, and operated in accordance with good engineering practices and the instructions contained in the Operating and Maintenance Manual. Failure to do so shall operate to void all warranties. Seller's total responsibility for damages whether arising in contract or tort arising out of or relating to the performance of the product or the warranties hereunder shall be strictly limited to the contract price for the product. In no event shall Seller be liable for any incidental or consequential damages such as lost profits, loss of use of productive facilities or equipment, expenses or damages incurred in reliance on the product's performance or lost production whether suffered by buyer or any third party.

Seller warrants that the products comply with OSHA standards on drive guard design and construction (if applicable) in effect at the time of manufacture and makes no other warranty with respect to any other standards. Seller shall not be responsible for failure of parts to fit properly due to deterioration of or modification to Buyer's existing equipment for which such parts are furnished.

Seller makes no warranty or guarantee that the product supplied hereunder will comply with the performance of Buyer's existing equipment.

Seller reserves the right to furnish substitutes for material not available or whose use is restricted.

The use of (a) non-OEM components or (b) non-OEM pump spare parts and/or (c) non-approved modifications to the product and/or (d) failure to install a moisture detection relay and/or (e) failure to connect the thermal overload protection wiring will operate to void all warranties.

We reserve the right to change the design, construction or material of any part without incurring the obligation of installing such changes on pumps already delivered.



INSTALLATION, OPERATION AND MAINTENANCE MANUAL POLARIS - SERIES TBM 200 LH (8") - TYPE PHO / PBO / PVO			6 of 29
DOCUMENT NBR. : PED-010	REVISION: 1	EFFECTIVE DATE:	08-24-2004

3.0 SAFETY

Do not install the equipment other than in accordance with the instructions contained in this manual.

When required information cannot be found in this manual, contact the nearest **POLARIS PUMPS** representative.

This instruction book should be read completely before starting installation, maintenance or operation. The equipment is capable of trouble free operation when properly installed, operated and maintained. These instructions present the basic information and methods required for proper installation and maintenance.

This pump has been designed to provide safe and reliable service, however as with all equipment of this type, the operator(s) must exercise good judgment and proper safety practices to avoid damage to the equipment and surroundings and to avoid personal injury. The instructions in this manual are intended for personnel with a general training in operation and maintenance of centrifugal pumps and electric motors.

It is assumed that your safety department has established a safety program based upon a thorough analysis of industrial hazards. Before installing, operating or performing maintenance on the pump and associated components described in this manual, it is suggested that the safety program be reviewed to ensure that it covers the hazards arising from rotating- and electrical machinery. In general, all personnel should be guided by all the basic rules of safety associated with the equipment and the process.

It should be understood that the information contained in this manual does not relieve operating and maintenance personnel of the responsibility of exercising normal good judgment in operation and care of the pump and its components.



INSTALLATION, OPERATION AND MAINTENANCE MANUAL			7 of 29
POLARIS - SERIES TBM 200 LH (8") - TYPE PHO / PBO / PVO			
DOCUMENT NBR. : PED-010	REVISION: 1	EFFECTIVE DATE:	08-24-2004

4.0 INSTALLATION

4.1 RECEIVING INSPECTION

The unit must be inspected immediately upon arrival and any irregularities and damages due to shipment must be reported to the carrier and **POLARIS PUMPS**. A copy of this manual is included in the shipment. Put this manual a safe, accessible place for ready reference when required. It is important that the entire contents of this manual are studied before installation.

Pump parts and accessories may be packed inside shipping container, or attached to skids in individual packages. Inspect all containers, crates and skids before discarding.

4.2 STORAGE

4.2.1 NEW PUMP AND EQUIPMENT STORAGE

If your new pump is to be stored for a long period before use, the following procedures must be adhered to in order for **POLARIS PUMPS** to extend the normal warranties.

Notify **POLARIS PUMPS** that the equipment is to be stored and that the storage procedures will be followed. Notify **POLARIS PUMPS** when the equipment is to be removed from storage and put into service.

Failure to notify **POLARIS PUMPS** will result in your warranty being void. Your new pump will arrive ready for use. Close off all flush and cooling water inlet ports and cooling water exhaust ports on water jackets. Suitable covers out of plywood or plastic must be installed on the suction entrance and discharge to provide adequate protection against dirt, dust and nesting animals. The main power and control cable ends must be protected by means of suitable shrink-on boots or similar to prevent the ingress of moisture during storage.

Equipment should be stored in a dry location and situated on an even surface with no strains applied. If stored outdoors, the equipment must be covered with a waterproof tarp secured to the equipment or skid.



INSTALLATION, OPERATION AND MAINTENANCE MANUAL			8 of 29
POLARIS - SERIES TBM 200 LH (8") - TYPE PHO / PBO / PVO			
DOCUMENT NBR. : PED-010	REVISION: 1	EFFECTIVE DATE:	08-24-2004

4.2.2 USED PUMP STORAGE

A used pump should be completely disassembled and all parts cleaned and inspected. All unpainted metal surfaces should be coated with grease or suitable protectant. All previously painted parts should be touched up or repainted. Reassemble the pump as per Sections **7.0** and store as per Section **4.2.1**.

4.2.3 SPARE PARTS STORAGE

Spare parts may not arrive at your site with adequate protection for long-term storage unless it was specified in your parts order. It is the customer's responsibility to ensure that all spare parts are prepared and packaged for long term storage. Components such as mechanical seal assemblies and parts should be left in their original sealed containers. The long-term storage of elastomer (rubber) parts must be given consideration since elastomers may have a short shelf live under certain circumstances.

4.3 HANDLING

Use care when moving pumps. Sling pumps so that any protruding components will not be damaged. Do not use choke type sling or chain arrangements for skids or containers.

Make sure that the lifting equipment is rated to safely handle the weight of the pump and auxiliary equipment.

See relevant general arrangement drawings (**Section 8.0**) or bills of materials for weight information.

4.4 MECHANICAL SEAL INSPECTION

The pump was checked during assembly and testing for proper alignment of the pump components. Rough handling during shipment, storage or preparation for installation could cause damage to mechanical seals. **POLARIS PUMPS** are equipped with tandem mechanical seals and should be checked for any oil leakage on the wet end side. This is to ensure that the seal faces did not receive any damage during shipment, storage or preparation for installation.



INSTALLATION, OPERATION AND MAINTENANCE MANUAL POLARIS - SERIES TBM 200 LH (8") - TYPE PHO / PBO / PVO			9 of 29
DOCUMENT NBR. : PED-010	REVISION: 1	EFFECTIVE DATE:	08-24-2004

4.5 PUMP SET UP / MOUNTING

4.5.1 CABLE AND CHAIN SUSPESION

Pumps of SERIES TBM are fitted with integral lifting lugs sized to accommodate the dead weight of the pump assembly. Verify the weight of your specific pump before making lifting cable or chain selection.

See relevant general arrangement drawings (**Section 8.0**) or bills of materials for weight information.

4.5.2 OPTIONAL LIFTING / SUSPENSION BAIL MOUNTING

Optional lifting bails are available for all pumps of SERIES TBM for applications where a single lifting cable or chain is preferred.

4.5.3 FLOOR MOUNTING

When Pumps are operated resting on the pump stand on the sump floor, they must rest on a horizontal surface that prevents the pump from tipping over and burying itself. A chain or cable with limited slack can be utilized to prevent this.

4.6 PIPING

4.6.1 DISCHARGE HOSE / DISCHARGE PIPING

Flexible, heavy duty, non-collapsible discharge hose is preferred. All rigid piping must be independently supported. Pump casing should never bear the weight of the piping. Non-collapsible, expansion type joints are recommended on the discharge side of the pump for rigid pipe installations.



INSTALLATION, OPERATION AND MAINTENANCE MANUAL POLARIS - SERIES TBM 200 LH (8") - TYPE PHO / PBO / PVO			10 of 29
DOCUMENT NBR. : PED-010	REVISION: 1	EFFECTIVE DATE:	08-24-2004

4.6.2 PRIMARY SEAL FLUSH

The seal flush / cooling water to the outboard mechanical seal is automatically supplied if the pump is running. Be aware that if the pump is operated in applications where the sump can be pumped dry, **a minimum water level must be present to prevent the mechanical seal from dry running.** If the sump level falls below the minimum requirement, the higher than normal seal temperatures can cause the seal faces to crack due to thermal shock once the sump water level rises back and quenches the hot seal faces.

Refer to the general arrangement drawing of your pump (Section 8.0) for the minimum sump level requirement and install suitable level controls.

4.6.3 OPTIONAL WATER JACKET / PIPING

An optional water jacket **must** be installed if the pump is operated in applications where the sump can be pumped dry below the minimum water level and the **pump remains running for periods exceeding 15 minutes.** This is to prevent overheating and subsequent burnout of the stator windings.

Cooling water should be 3 GPM at 60 P.S.I. maximum pressure at a temperature not exceeding 40°C (104°F).

Water must be **clean** so that no sand, etc., is pumped into the water jacket.



INSTALLATION, OPERATION AND MAINTENANCE MANUAL			11 of 29
POLARIS - SERIES TBM 200 LH (8") - TYPE PHO / PBO / PVO			
DOCUMENT NBR. : PED-010	REVISION: 1	EFFECTIVE DATE:	08-24-2004

5.0 ELECTRICAL INSTALLATION

5.1 GENERAL

Power supply and electrical work must be as per local and national codes. All wiring and installation of cables, relays, disconnects, etc., should be performed by qualified personnel. Check that main line voltage and frequency agree with the specifications on the motor data plate. Prior to installation of any wiring, inspect both main power and control cable for possible cuts and tears.

5.2 MOISTURE SENSOR RELAY

Failure to install / operate the specified Motor Moisture-Detection Relay and not connecting the thermal over-load wiring will void your Warranty.

POLARIS PUMPS requires the use of a **Warrick Controls - Type 2810** moisture detection relay. This relay must be purchased with your pump as an integral part of the package to validate your warranty.

See **Section 8.3** for dimensional information and wiring diagram.

5.3 INSTALLATION

All activities related to the electrical installation, maintenance and operation and service of the motor module must be in accordance with the

RELIANCE ELECTRIC
Application, Installation & Operation Manual
Duty Master[®] Submersible Motors

See **Section 8.2** of this pump manual.



INSTALLATION, OPERATION AND MAINTENANCE MANUAL			12 of 29
POLARIS - SERIES TBM 200 LH (8") - TYPE PHO / PBO / PVO			
DOCUMENT NBR. : PED-010	REVISION: 1	EFFECTIVE DATE:	08-24-2004

6.0 OPERATION

6.1 PRE-START UP CHECK

A pre-start up check should always be performed prior to putting your pump into service. The following procedures should be adhered to as a minimum.

- **POWER SUPPLY**

Double-check and confirm that the power supply voltage and frequency match with the pump data plate.

- **WIRING**

Double-check all power and control cable connections. Check and confirm that all ground leads are connected and properly grounded.

- **CONTROL SYSTEM**

Double-check that all control equipment is powered up and operational.

- **CABLES**

Inspect both power and control cables for visual damage such as cuts and tears in the jacket.

- **OIL LEVEL**

Double-check the motor seal oil level

- **ROTATION CHECK**

Correct rotation is counter clock wise as viewed from the pump intake side. In case of wrong rotation, switch two of the three main power leads. Do not run the pump in air longer than required to verify proper rotation.

- **COOLING AND FLUSH WATER**

Double-check all connections, hoses and piping and ensure that the water supply is turned on for applications requiring motor cooling. Visually confirm that the cooling water is circulating and exiting through the exhaust opening of the water jacket prior to start up.



INSTALLATION, OPERATION AND MAINTENANCE MANUAL			13 of 29
POLARIS - SERIES TBM 200 LH (8") - TYPE PHO / PBO / PVO			
DOCUMENT NBR. : PED-010	REVISION: 1	EFFECTIVE DATE:	08-24-2004

6.2 PUMP START UP

Whenever possible, start the pump in clear liquid to prime discharge piping and/or hoses. If flexible hoses are used, make sure that they are not pinched since the pressure developed by the pump may not be enough to force them open.

Lower the pump slowly into the material to be pumped.

Mixture density can be monitored via a current meter. Higher current draw of the pump will indicate higher density and therefore higher production rate. The mixture density can be controlled by raising or lowering the pump into the material.

Be aware of the mixture characteristics for your specific application. It is important that you maintain a pipeline velocity above the critical settling velocity of the solids mixture being pumped to prevent the solids from settling out and clogging the discharge line.

Never stop the pump while pumping solids through the system. This will plug the piping. Before shut down, raise the pump into clean water and completely flush the discharge line.

During the initial few days of operation while all parts are still new, observe the discharge gauge readings as well as the motor amperage draw. If a flow meter is available, monitor the pump output as well.

These readings should be taken and recorded periodically and will help you to establish an inspection and maintenance schedule. Keeping track of your pumps performance will make it easier to identify problems before they become serious and cause undue damage.



INSTALLATION, OPERATION AND MAINTENANCE MANUAL			14 of 29
POLARIS - SERIES TBM 200 LH (8") - TYPE PHO / PBO / PVO			
DOCUMENT NBR. : PED-010	REVISION: 1	EFFECTIVE DATE:	08-24-2004

6.3 PUMP SHUT DOWN

Never stop the pump while pumping solids through the system. This will plug the piping. Lift the pump into clear fluid for as long as it takes to flush the entire system of any slurry.

IMPORTANT

If you operate and store your pump in environments subject to below-freezing temperatures:

1. After the pump has been shut down, completely drain wet end, water jacket and piping. Failure to do so will result in serious damage to your equipment.
2. Be aware that the motor seal oil can thicken during cold storage to the point where it will be too viscous and can not provide adequate lubrication for start-up. Pre-heat the pump as required before start up.
3. Be aware that certain elastomer components (lip seals, o-rings etc.) must not be operated if their temperature is below -4°F (-20°C). Pre-heat the pump as required before start up.



INSTALLATION, OPERATION AND MAINTENANCE MANUAL			15 of 29
POLARIS - SERIES TBM 200 LH (8") - TYPE PHO / PBO / PVO			
DOCUMENT NBR. : PED-010	REVISION: 1	EFFECTIVE DATE:	08-24-2004

6.4 TROUBLE SHOOTING

6.4.1 FAULT TRACING

To carry out fault tracing on electrical equipment, a multi-meter, test lamp and wiring diagram are required. Fault tracing must be done with the power disconnected unless checks cannot be performed without power to the motor. If a fault is detected, be sure to keep all personnel clear of the pump when the power is turned on. A qualified electrician must perform all electrical work. Obey all local codes and regulations and follow recommended safety procedures.

The following Checklist is designed to aid in identifying possible faults, assuming the pump has been in operation and functioned previously.

All activities related to the electrical installation, maintenance and operation and service of the motor module must be in accordance with the

RELIANCE ELECTRIC
Application, Installation & Operation Manual
Duty Master® Submersible Motors

See **Section 8.2** of this pump manual.

- **FAULT SIGNAL AT THE STARTER**

If the stator temperature is too high, check that the pump motor is completely submerged or that the water supply to the water jacket is turned on during operation and that the impeller rotates freely.

In case of a moisture sensor fault, check the condition of the oil and check for water in the motor housing and oil sump. Make sure the overload protection is reset.



INSTALLATION, OPERATION AND MAINTENANCE MANUAL			16 of 29
POLARIS - SERIES TBM 200 LH (8") - TYPE PHO / PBO / PVO			
DOCUMENT NBR. : PED-010	REVISION: 1	EFFECTIVE DATE:	08-24-2004

- **FAULT SIGNAL AT THE STARTER, PUMP CAN BE STARTED MANUALLY**

Check for faulty level-control system components (start or high water sensors). Clean or replace as required.

Check for faulty control equipment. Check that all connections are intact. Check relay and actuator windings. Test actuator switch for contact in both manual and automatic mode.

- **PUMP CAN NOT BE STARTED MANUALLY, NO VOLTAGE TO PUMP**

Check that the main power switch is on. Check for control voltage to the starter equipment and that all fuses are intact.

Check that all supply line phases are live and that all fuses are intact and properly fitted. Check that the overload protection relay is reset. Check for breaks in the motor cable.

- **PUMP CAN NOT BE STARTED MANUALLY, VOLTAGE IS GOING TO PUMP**

If this is the case, some oversized material or other debris may have jammed the impeller, solids mixer or shredder.

CAUTION: Disconnect and lock out the main power supply before working in the intake area of the pump. Failure to do so can result in serious injury.

Clean out and remove any objects that may have jammed the impeller and inspect the pump components for any visual damage. Inspect the sump area and remove any oversized material and debris. Inspect pump strainer for excessive wear and replace if required.

- **PUMP CAN BE STARTED, MOTOR PROTECTION TRIPS**

Check that the overload protection is not set too low or is defective. Check the breaker set point vs. the amperage on the motor data plate and adjust or replace overload protection relay as required.

Check for free rotation of the impeller. If it is not easily rotated, or feels tight, check for tramp material within the pump. Using an Amp-meter, check the current on all three phases. Using a Meg-ohm meter, check the insulation between the phases and ground. If the phase amp readings are too high or uneven, or a ground fault is detected, contact **POLARIS PUMPS**.



INSTALLATION, OPERATION AND MAINTENANCE MANUAL			17 of 29
POLARIS - SERIES TBM 200 LH (8") - TYPE PHO / PBO / PVO			
DOCUMENT NBR. : PED-010	REVISION: 1	EFFECTIVE DATE:	08-24-2004

- **PUMP IS EXPECTED TO STOP BUT KEEPS RUNNING**

If the pump has been running satisfactory and is capable of emptying the sump to the control stop level, check for leakage in discharge piping and connections. Leakage water may be re-circulated back into the sump. Check that the impeller or suction is not clogged.

CAUTION: Disconnect and lock out the main power supply before working in the intake area of the pump. Failure to do so can result in serious injury. Clean out and remove any objects that may have clogged the impeller and inspect the pump components for any visual damage. Inspect the sump area and remove any oversized material and debris. Inspect pump strainer for excessive wear and replace if required. Check that the impeller and casing are not worn and need to be replaced. Check the impeller running clearance and adjust as required.

Check for faults in the level control equipment. Clean and inspect the level sensor probes and perform a function test. Check the level control relay contactor and holding circuit. Replace any faulty components. Check the location of the stop level probe to ensure it is not set too low.

- **PUMP STARTS AND STOPS REPEATEDLY**

Check if the back flow from the discharge pipe is enough to raise the sump level to the level-controller starting probe. If so, positioning a rubber flap valve in the discharge pipe close enough to the pump will minimize back-flow. Check that the distance between start and stop level probes is not too short. Check that the contactor does not break its self-holding function. Check the voltage in the control circuit in relation to the rated voltage on the coil. Check the functioning of the stop sensor probe. The voltage drop in the line during the start-up surge can cause the contactor self-holding function to break.



INSTALLATION, OPERATION AND MAINTENANCE MANUAL			18 of 29
POLARIS - SERIES TBM 200 LH (8") - TYPE PHO / PBO / PVO			
DOCUMENT NBR. : PED-010	REVISION: 1	EFFECTIVE DATE:	08-24-2004

- **PUMP IS RUNNING WITH REDUCED FLOW**

This can be caused by either pump and / or system related problems.

Check your system set-up:

Verify that all piping connections are tight and that there are no leaks in the discharge line.

Check that any valves are fully open and operable and the discharge line and valves are not clogged.

Check your system-head requirement. The pump flow will reduce if the point of discharge has been raised or additional piping has been added.

Check your pump:

Verify proper direction of rotation.

Check the pump intake area to ensure that the impeller, strainer and mixer or shredder is not clogged.

Visually inspect the wet-end components for wear. The performance of the pump can be significantly reduced if casing and impeller have experienced excessive wear. Check the impeller running clearance and adjust if required. Replace parts as required.



INSTALLATION, OPERATION AND MAINTENANCE MANUAL			19 of 29
POLARIS - SERIES TBM 200 LH (8") - TYPE PHO / PBO / PVO			
DOCUMENT NBR. : PED-010	REVISION: 1	EFFECTIVE DATE:	08-24-2004

7.0 WET END INSTALLATION

Inspect and inventory all parts before you begin assembly. Clean all parts and remove protective coatings as required. Inspect the motor module for any visual damage paying particular attention to the shaft end and mechanical seal. Remove any protective coatings from the shaft end and check to make sure that the tapped hole in the end of the shaft and the key seat are free of any shavings and dirt. Prior to the physical assembly of the wet end, familiarize yourself with all of the components and the assembly sequence by reading the assembly instructions and the enclosed explosion drawings. Based on your particular pump model and size gather the necessary tools as per the following tool list.

TOOL REQUIREMENTS

Series TBM - 200 LH - Type "PHO"

- Allen wrenches 5/8" - 14 mm - 6 mm
- Plastic or Rubber Hammer
- "Never-Seize" or "Molykote", "Loctite"

Series TBM - 200 LH - Types "PBO" and "PVO"

- Allen wrenches 5/8" - 14 mm - 8 mm - 5 mm
- Open ended wrench 2" or 51 mm
- Plastic or Rubber Hammer
- "Never-Seize" or "Molykote", "Loctite"



INSTALLATION, OPERATION AND MAINTENANCE MANUAL			20 of 29
POLARIS - SERIES TBM 200 LH (8") - TYPE PHO / PBO / PVO			
DOCUMENT NBR. : PED-010	REVISION: 1	EFFECTIVE DATE:	08-24-2004

7.1 TBM 200 LH - TYPE PHO Drawing **A0207 and **A0210****

Apply "Never-Seize" to the motor shaft end. Position Flinger Gasket (Item 060.2) onto shaft. Insert Drive Key (Item 113) into the key seat. Slide Flinger (Item 110) onto the shaft. Position Impeller Gasket (Item 060.1) against the Impeller flinger.

Hoist the Volute Casing (Item 102) into position and insert into the motor flange spigot. Apply "Never-Seize" to the Socket Head Cap Screws and insert with Lock Washers (Items 040.1, 040.4) through the motor flange into the Casing and tighten.

Slide the Impeller (Item 101) onto the shaft. Position the O-ring (Item 062.2) onto the Impeller Cap (Item 107) and the same into the impeller bore, lining up the groove in the cap face with the key. Position O-Ring (Item 062.1) onto the Impeller Lock Screw (Item 040.3), apply "Locktite" and insert into the shaft end and tighten.

Refer to Appendix - 8.4 for Impeller Lock Screw Torque and Procedure

Position Casing Gaskets (Item 060.3) onto Strainer (Item 103), aligning the holes. To verify the impeller running clearance, compare the depth from the top of the strainer to the gaskets with the depth from the casing face to the impeller vanes. The total difference should be 1/32" – 1/16". Adjust as necessary by adding or subtracting casing gaskets.

Slide strainer and gaskets into the casing bore. Position the Pump Stand (Item 112) over the strainer, insert "Never-Seize" coated Socket Head Cap Screws and Lock Washers (Items 040.2, 040.4) and tighten.

Apply "Never-Seize" to the Countersunk Head Cap Screws (Item 040.5), insert the Intake Screen (Item 111) and screws into the strainer and tighten.

POLARIS

P U M P S

Pump'n Hard Iron

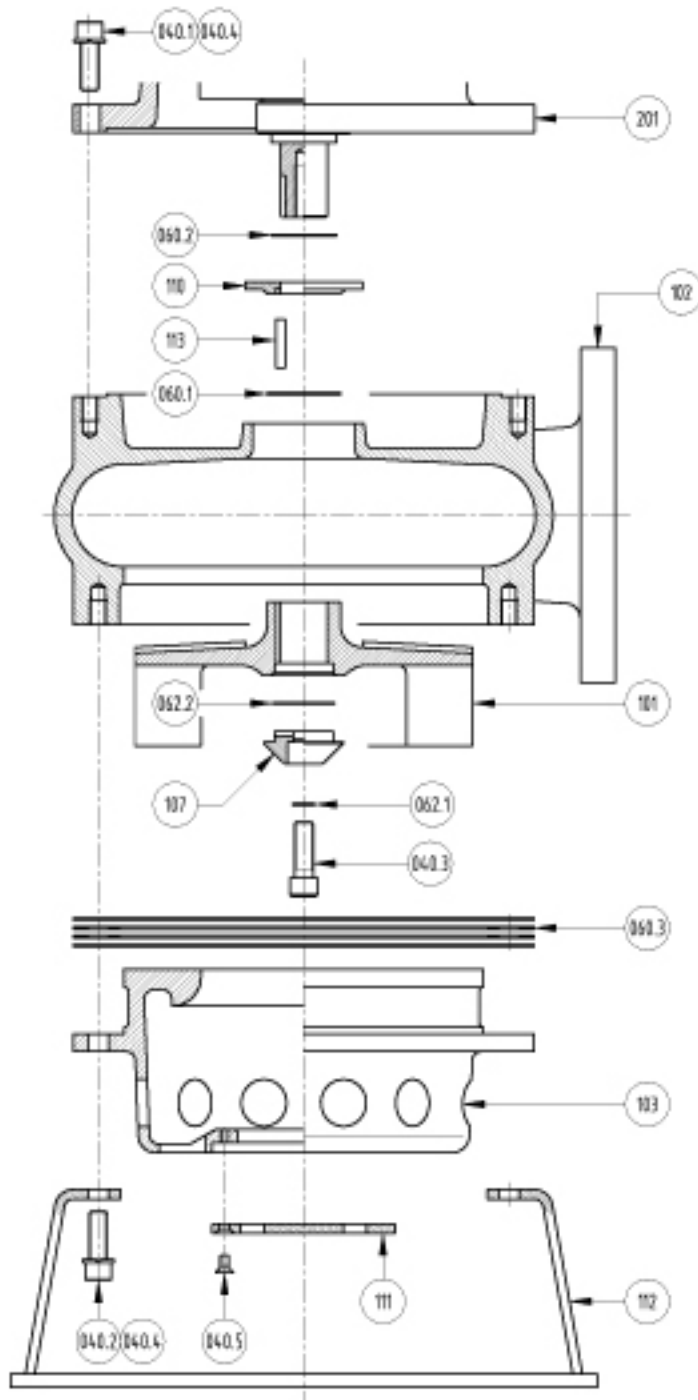

WET END ASSEMBLY - EXPLOSION

TBM 200 LH-PHD

DRAWING NBR.: **A0207**

REV.: **1**

EFFECTIVE DATE : **08-09-01**

FOR BILL OF MATERIALS / PARTS LIST SEE:

A0210



POLARIS PUMPS - SERIES TBM - 200 LH TYPE PHO											A0210 (Rev.0) 1/2	
ITEM	ITEM	ITEM	PART NUMBER	QTY.	DESCRIPTION	EXT. DESC.1	MODEL1	MODEL 2	WT.(KG)	WT.(lbs)	MTL.	DWG. #
151			151.200.05.00240	1	KIT, WET END - BASIC		TBM 200LH		375.57	826.37		
	101		101.012.05.00213	1	IMPELLER	RH, 5V	TBM 200LH	PHO, PBO, PVO			A532 CL III TP. A	C0182
	102		102.012.05.00215	1	CASING	VOLUTE	TBM 200LH	PHO, PBO, PVO			A532 CL III TP. A	D0184
	103		103.012.05.00217	1	LINER	SUCTION	TBM 200LH	PHO, PBO, PVO			A532 CL III TP. A	D0186
	110		110.082.05.00228	1	FLINGER		TBM 200LH	FRAME 320TY/360TYS			ASTM A564 Gr.630 (17-4 PH)	B0193
	112		112.056.05.00231	1	STAND	PUMP	TBM 200LH	PHO, PBO, PVO			ASTM A36	C0197
	113		113.052.05.00235	1	KEY	DRIVE	FRAME 320TY/360TYS	PHO, PBO, PVO			SAE 1045	B0111
	041.1		041.200.05.00260	1	KIT, FASTENER						A4/70	
		040.1	040.084.00.00254	8	FASTENER	SCREW	HEX SOCKT.HD.CAP	DIN 912 / M16 X 55			A4/70	
		040.2	040.084.00.00255	8	FASTENER	SCREW	HEX SOCKT.HD.CAP	DIN 912 / M16 X 70			A4/70	
		040.3	040.084.00.00257	1	FASTENER	SCREW	HEX SOCKT.HD.CAP	ANSI B18.3 / 3/4"UNC X 2.50"			A4/70	
		040.4	040.084.00.00070	16	FASTENER	WASHER	LOCK	DIN 127B / M16				
	061.1		061.200.05.00252	1	KIT, GASKET						GYLON-3500	
		060.1	060.101.05.00232	1	GASKET	IMPELLER	FRAME 320 TY / 360 TYS	PHO, PBO, PVO			GYLON-3500, .031"	B0044
		060.2	060.101.05.00233	1	GASKET	FLINGER	FRAME 320 TY / 360 TYS	PHO, PBO, PVO			GYLON-3500, .031"	B0044
	061.2		061.200.05.00253	1	KIT, GASKET						BLUE-GARD	
		060.3	060.102.05.00234	4	GASKET	CASING	TBM200LH	PHO, PBO, PVO			"BLUE GARD", .125"	B0045
152			152.200.05.00241	1	KIT, INTAKE SCREEN		TBM 200LH	PHO	3.57	7.85		
	111		111.053.05.00229	1	SCREEN	INTAKE	TBM 200LH	PHO			QT400	B0195
	041.2		041.200.05.00261	1	KIT, FASTENER						A4/70	
		040.5	040.084.00.00258	3	FASTENER	SCREW	HEX SOCKT, CSK.HD.FLAT	DIN 7991 / M12 X 30			A4/70	
153			153.200.05.00242	1	KIT, IMPELLER CAP		TBM 200LH	PHO	1.75	3.85		
	107		107.082.05.00225	1	CAP	IMPELLER	TBM 200LH	PHO			ASTM A564 Gr.630 (17-4 PH)	B0191
	063.1		063.200.05.00246	1	KIT, O-RING						72 NBR	
		062.1	062.131.00.00249	1	O-RING	18 x 2					72 NBR	
		062.2	062.131.00.00248	1	O-RING	80 x 3					72 NBR	
SEE TABLE BELOW FOR COMPLETE PUMP PART NUMBERS AND MOTOR DETAILS									380.89	838.07	ESTIMATED WEIGHT	TOTAL



INSTALLATION, OPERATION AND MAINTENANCE MANUAL			23 of 29
POLARIS - SERIES TBM 200 LH (8") - TYPE PHO / PBO / PVO			
DOCUMENT NBR. : PED-010	REVISION: 1	EFFECTIVE DATE:	08-24-2004

7.2 TBM 200 LH - TYPE PBO Drawing **A0208 and **A0211****

Apply "Never-Seize" to the motor shaft end. Position Flinger Gasket (Item 060.2) onto shaft. Insert Drive Key (Item 113) into the key seat. Slide Flinger (Item 110) onto the shaft. Position Impeller Gasket (Item 060.1) against the Impeller flinger.

Hoist the Volute Casing (Item 102) into position and insert into the motor flange spigot. Apply "Never-Seize" to the Socket Head Cap Screws and insert with Lock Washers (Items 040.1, 040.4) through the motor flange into the Casing and tighten.

Slide the Impeller (Item 101) onto the shaft. Position the O-rings (Item 062.2, 062.3) onto the Shaft Adapter (Item 108) and the same into the impeller bore, lining up the groove in the cap face with the key. Position O-Ring (Item 062.1) onto the Impeller Lock Screw (Item 040.3), apply "Loctite" and insert into the shaft end and tighten.

Refer to Appendix - 8.4 for Impeller Lock Screw Torque and Procedure

Apply "Never-Seize" to the adapter thread and screw on the Shaft Extension (Item 109). Tighten the shaft extension via the wrench flats on the outboard end. Position the O-ring (Item 062.4) into the shaft extension thread relief.

Position Casing Gaskets (Item 060.3) onto Strainer (Item 103), aligning the holes. To verify the impeller running clearance, compare the depth from the top of the strainer to the gaskets with the depth from the casing face to the impeller vanes. The total difference should be 1/32" – 1/16". Adjust as necessary by adding or subtracting casing gaskets.

Slide strainer and gaskets into the casing bore. Position the Pump Stand (Item 112) over the strainer, insert "Never-Seize" coated Socket Head Cap Screws and Lock Washers (Items 040.2, 040.4) and tighten.

Apply "Never-Seize" to the Countersunk Head Cap Screws (Item 040.5), insert the Intake Screen (Item 111) and screws into the strainer and tighten.

Apply "Never-Seize" to the shaft extension thread and screw on the Solids Mixer (Item 106). Tighten using a plastic or rubber hammer.

POLARIS

P U M P S

Pump'n Hard Iron

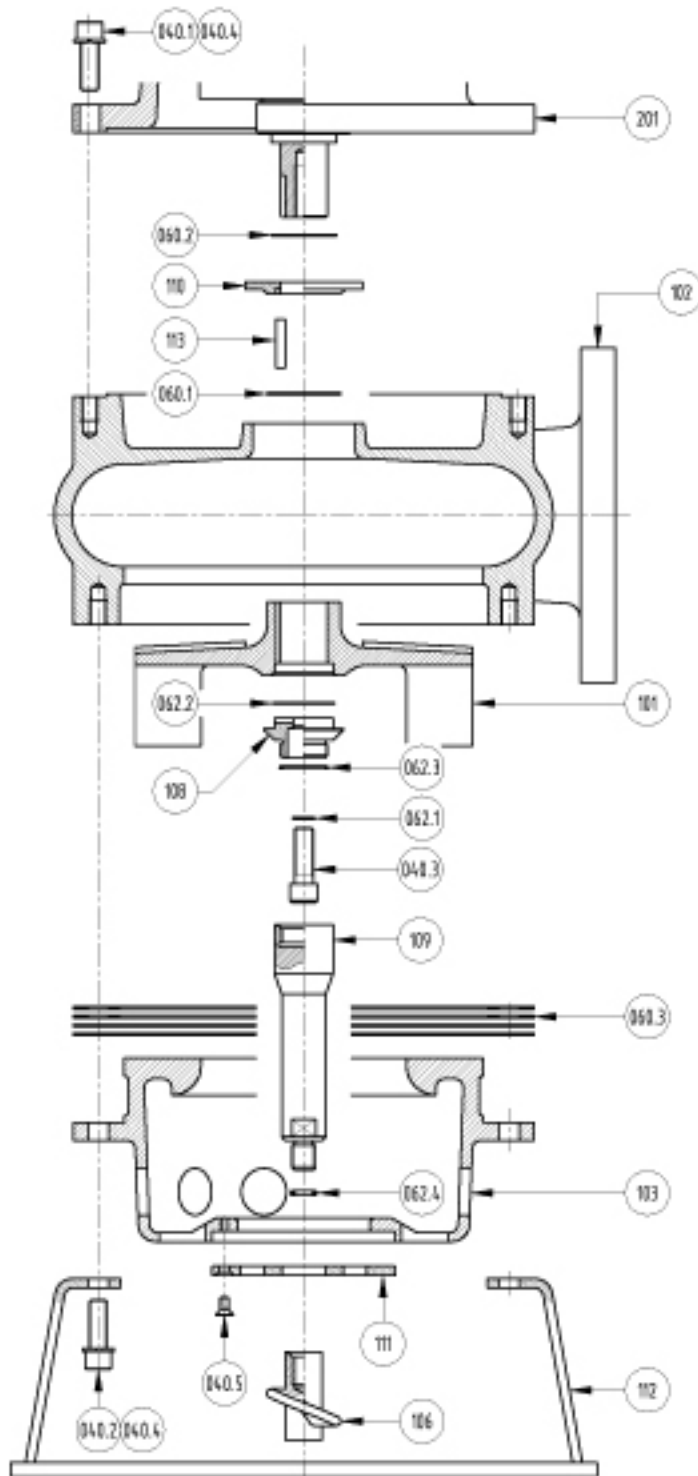

WET END ASSEMBLY - EXPLOSION

TBM 200 LH-P80

DRAWING NBR.: A0208

REV.: 1

EFFECTIVE DATE : 08-09-01

FOR BILL OF MATERIALS / PARTS LIST SEE:

A0211



POLARIS PUMPS - SERIES TBM - 200 LH TYPE PBO											A0211 (Rev.0) 1/2	
ITEM	ITEM	ITEM	PART NUMBER	QTY.	DESCRIPTION	EXT. DESC.1	MODEL1	MODEL 2	WT.(KG)	WT.(lbs)	MTL.	DWG. #
151			151.200.05.00240	1	KIT, WET END - BASIC		TBM 200LH		375.57	826.37		
	101		101.012.05.00213	1	IMPELLER	RH, 5V	TBM 200LH	PHO, PBO, PVO			A532 CL III TP. A	C0182
	102		102.012.05.00215	1	CASING	VOLUTE	TBM 200LH	PHO, PBO, PVO			A532 CL III TP. A	D0184
	103		103.012.05.00217	1	LINER	SUCTION	TBM 200LH	PHO, PBO, PVO			A532 CL III TP. A	D0186
	110		110.082.05.00228	1	FLINGER		TBM 200LH	FRAME 320TY/360TYS			ASTM A564 Gr.630 (17-4 PH)	B0193
	112		112.056.05.00231	1	STAND	PUMP	TBM 200LH	PHO, PBO, PVO			ASTM A36	C0197
	113		113.052.05.00235	1	KEY	DRIVE	FRAME 320TY/360TYS	PHO, PBO, PVO			SAE 1045	B0111
	041.1		041.200.05.00260	1	KIT, FASTENER						A4/70	
		040.1	040.084.00.00254	8	FASTENER	SCREW	HEX SOCKT.HD.CAP	DIN 912 / M16 X 55			A4/70	
		040.2	040.084.00.00255	8	FASTENER	SCREW	HEX SOCKT.HD.CAP	DIN 912 / M16 X 70			A4/70	
		040.3	040.084.00.00257	1	FASTENER	SCREW	HEX SOCKT.HD.CAP	ANSI B18.3 / 3/4"UNC X 2.50"			A4/70	
		040.4	040.084.00.00070	16	FASTENER	WASHER	LOCK	DIN 127B / M16				
	061.1		061.200.05.00252	1	KIT, GASKET						GYLON-3500	
		060.1	060.101.05.00232	1	GASKET	IMPELLER	FRAME 320 TY / 360 TYS	PHO, PBO, PVO			GYLON-3500, .031"	B0044
		060.2	060.101.05.00233	1	GASKET	FLINGER	FRAME 320 TY / 360 TYS	PHO, PBO, PVO			GYLON-3500, .031"	B0044
	061.2		061.200.05.00253	1	KIT, GASKET						BLUE-GARD	
		060.3	060.102.05.00234	4	GASKET	CASING	TBM200LH	PHO, PBO, PVO			"BLUE GARD", .125"	B0045
154			154.200.05.00243	1	KIT, MIXER		TBM 200LH	PBO	6.37	14.05		
	106		106.012.05.00223	1	MIXER	ROTATING	TBM 200LH	PBO			A532 CL III TP. A	C0188
	111		111.053.05.00230	1	SCREEN	INTAKE	TBM 200LH	PBO			QT400	B0196
	041.2		041.200.05.00261	1	KIT, FASTENER						A4/70	
		040.5	040.084.00.00258	3	FASTENER	SCREW	HEX SOCKT, CSK.HD.FLAT	DIN 7991 / M12 X 30			A4/70	
156			156.200.05.00245	1	KIT, SHAFT EXTENSION		TBM 200LH	PBO, PVO	1.75	3.85		
	108		108.082.05.00226	1	ADAPTER	SHAFT	TBM 200LH	PBO, PVO			ASTM A564 Gr.630 (17-4 PH)	B0192
	109		109.082.05.00227	1	EXTENSION	SHAFT	TBM 200LH	PBO, PVO			ASTM A564 Gr.630 (17-4 PH)	B0190
	063.1		063.200.05.00246	1	KIT, O-RING						72 NBR	
		062.1	062.131.00.00249	1	O-RING	18 x 2					72 NBR	
		062.2	062.131.00.00248	1	O-RING	80 x 3					72 NBR	
	063.2		063.200.05.00247	1	KIT, O-RING						72 NBR	
		062.3	062.131.00.00250	1	O-RING	50 x 3					72 NBR	
		062.4	062.131.00.00251	1	O-RING	20 x 6					72 NBR	
SEE TABLE BELOW FOR COMPLETE PUMP PART NUMBERS AND MOTOR DETAILS									383.69	844.27	ESTIMATED WEIGHT	TOTAL



INSTALLATION, OPERATION AND MAINTENANCE MANUAL			26 of 29
POLARIS - SERIES TBM 200 LH (8") - TYPE PHO / PBO / PVO			
DOCUMENT NBR. : PED-010	REVISION: 1	EFFECTIVE DATE:	08-24-2004

7.3 TBM 200 LH - TYPE PVO Drawing **A0209 and **A0212****

Apply "Never-Seize" to the motor shaft end. Position Flinger Gasket (Item 060.2) onto shaft. Insert Drive Key (Item 113) into the key seat. Slide Flinger (Item 110) onto the shaft. Position Impeller Gasket (Item 060.1) against the Impeller flinger.

Hoist the Volute Casing (Item 102) into position and insert into the motor flange spigot. Apply "Never-Seize" to the Socket Head Cap Screws and insert with Lock Washers (Items 040.1, 040.4) through the motor flange into the Casing and tighten.

Slide the Impeller (Item 101) onto the shaft. Position the O-rings (Item 062.2, 062.3) onto the Shaft Adapter (Item 108) and the same into the impeller bore, lining up the groove in the cap face with the key. Position O-Ring (Item 062.1) onto the Impeller Lock Screw (Item 040.3), apply "Loctite" and insert into the shaft end and tighten.

Refer to Appendix - 8.4 for Impeller Lock Screw Torque and Procedure

Apply "Never-Seize" to the adapter thread and screw on the Shaft Extension (Item 109). Tighten the shaft extension via the wrench flats on the outboard end. Position the O-ring (Item 062.4) into the shaft extension thread relief.

Position Casing Gaskets (Item 060.3) onto Strainer (Item 103), aligning the holes. To verify the impeller running clearance, compare the depth from the top of the strainer to the gaskets with the depth from the casing face to the impeller vanes. The total difference should be 1/32" – 1/16". Adjust as necessary by adding or subtracting casing gaskets.

Slide strainer and gaskets into the casing bore. Position the Pump Stand (Item 112) over the strainer, insert "Never-Seize" coated Socket Head Cap Screws and Lock Washers (Items 040.2, 040.4) and tighten.

Apply "Never-Seize" to the Socket Head Cap Screws (Item 040.6) insert the Stationary Shredder (Item 105) and screws into the strainer. Insert Set-Screws (Item 040.7) into stationary shredder. Apply "Never-Seize" to the shaft extension thread and screw on the Rotating Shredder (Item 104). Tighten using a plastic or rubber hammer. Adjust shredder clearance to 0.5 mm (0.020") using the set-screws and tighten the socket head cap screws.

POLARIS

P U M P S

Pump'n Hard Iron

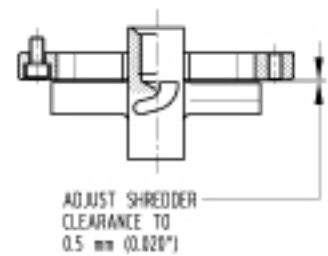
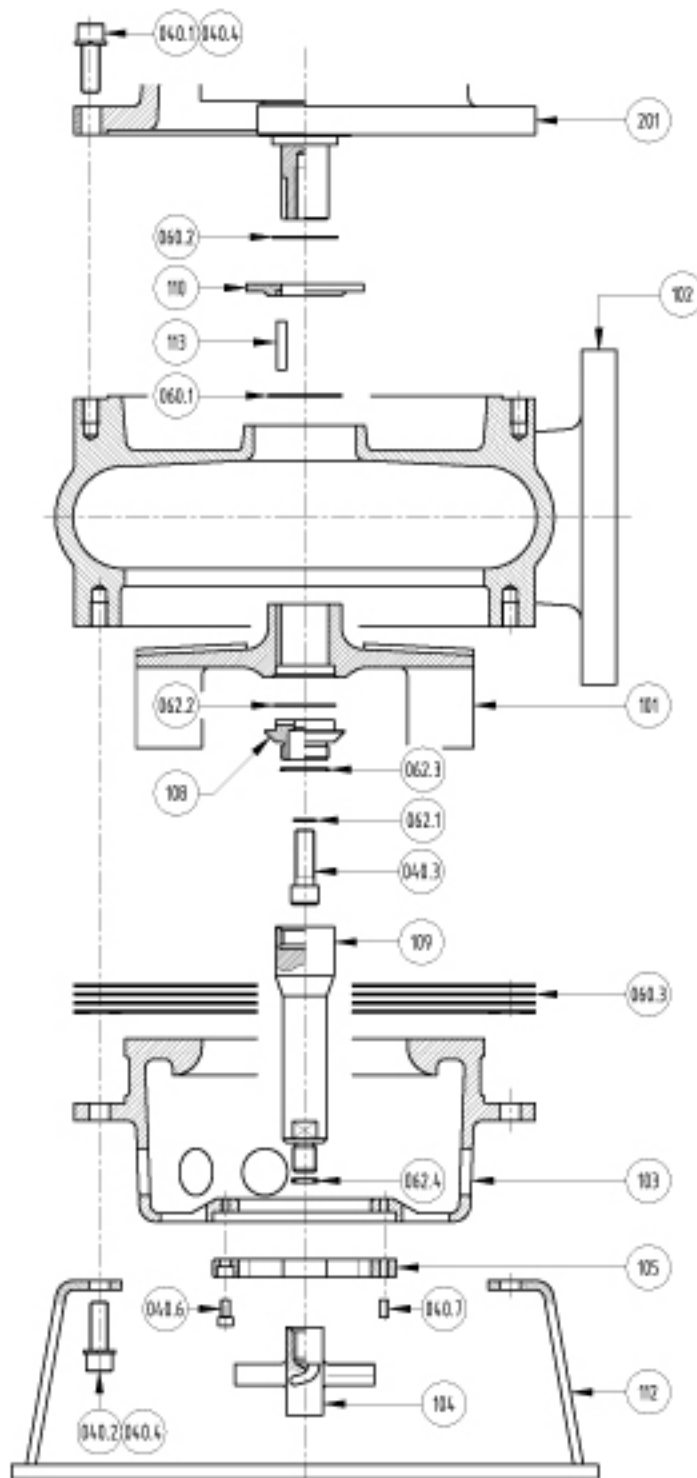

WET END ASSEMBLY - EXPLOSION

TBM 200 LH-PVO

DRAWING NBR.: A0209

REV.: 1

EFFECTIVE DATE : 08-09-01

FOR BILL OF MATERIALS / PARTS LIST SEE:

A0212



POLARIS PUMPS - SERIES TBM - 200 LH TYPE PVO											A0211 (Rev.0) 1/2	
ITEM	ITEM	ITEM	PART NUMBER	QTY.	DESCRIPTION	EXT. DESC.1	MODEL1	MODEL 2	WT.(KG)	WT.(lbs)	MTL.	DWG. #
151			151.200.05.00240	1	KIT, WET END - BASIC		TBM 200LH		375.57	826.37		
	101		101.012.05.00213	1	IMPELLER	RH, 5V	TBM 200LH	PHO, PBO, PVO			A532 CL III TP. A	C0182
	102		102.012.05.00215	1	CASING	VOLUTE	TBM 200LH	PHO, PBO, PVO			A532 CL III TP. A	D0184
	103		103.012.05.00217	1	LINER	SUCTION	TBM 200LH	PHO, PBO, PVO			A532 CL III TP. A	D0186
	110		110.082.05.00228	1	FLINGER		TBM 200LH	FRAME 320TY/360TYS			ASTM A564 Gr.630 (17-4 PH)	B0193
	112		112.056.05.00231	1	STAND	PUMP	TBM 200LH	PHO, PBO, PVO			ASTM A36	C0197
	113		113.052.05.00235	1	KEY	DRIVE	FRAME 320TY/360TYS	PHO, PBO, PVO			SAE 1045	B0111
	041.1		041.200.05.00260	1	KIT, FASTENER						A4/70	
		040.1	040.084.00.00254	8	FASTENER	SCREW	HEX SOCKT.HD.CAP	DIN 912 / M16 X 55			A4/70	
		040.2	040.084.00.00255	8	FASTENER	SCREW	HEX SOCKT.HD.CAP	DIN 912 / M16 X 70			A4/70	
		040.3	040.084.00.00257	1	FASTENER	SCREW	HEX SOCKT.HD.CAP	ANSI B18.3 / 3/4"UNC X 2.50"			A4/70	
		040.4	040.084.00.00070	16	FASTENER	WASHER	LOCK	DIN 127B / M16				
	061.1		061.200.05.00252	1	KIT, GASKET						GYLON-3500	
		060.1	060.101.05.00232	1	GASKET	IMPELLER	FRAME 320 TY / 360 TYS	PHO, PBO, PVO			GYLON-3500, .031"	B0044
		060.2	060.101.05.00233	1	GASKET	FLINGER	FRAME 320 TY / 360 TYS	PHO, PBO, PVO			GYLON-3500, .031"	B0044
	061.2		061.200.05.00253	1	KIT, GASKET						BLUE-GARD	
		060.3	060.102.05.00234	4	GASKET	CASING	TBM200LH	PHO, PBO, PVO			"BLUE GARD", .125"	B0045
155			155.200.05.00244	1	KIT, SHREDDER		TBM 200LH	PVO	7.50	16.50		
	104		104.012.05.00219	1	SHREDDER	ROTATING	TBM 200LH	PVO			A532 CL III TP. A	C0200
	105		105.012.05.00221	1	SHREDDER	STATIONARY	TBM 200LH	PVO			A532 CL III TP. A	C0202
	041.2		041.200.05.00262	1	KIT, FASTENER						A4/70	
		040.6	040.084.00.00256	3	FASTENER	SCREW	HEX SOCKT.HD.CAP	DIN 912 / M12 X 35			A4/70	
		040.7	040.084.00.00259	3	FASTENER	SCREW	HEX SOCKT.SET	DIN 913 / M12 X 20			A4/70	
156			156.200.05.00245	1	KIT, SHAFT EXTENSION		TBM 200LH	PBO, PVO	7.80	17.16		
	108		108.082.05.00226	1	ADAPTER	SHAFT	TBM 200LH	PBO, PVO			ASTM A564 Gr.630 (17-4 PH)	B0192
	109		109.082.05.00227	1	EXTENSION	SHAFT	TBM 200LH	PBO, PVO			ASTM A564 Gr.630 (17-4 PH)	B0190
	063.1		063.200.05.00246	1	KIT, O-RING						72 NBR	
		062.1	062.131.00.00249	1	O-RING	18 x 2					72 NBR	
		062.2	062.131.00.00248	1	O-RING	80 x 3					72 NBR	
	063.2		063.200.05.00247	1	KIT, O-RING						72 NBR	
		062.3	062.131.00.00250	1	O-RING	50 x 3					72 NBR	
		062.4	062.131.00.00251	1	O-RING	20 x 6					72 NBR	
SEE TABLE BELOW FOR COMPLETE PUMP PART NUMBERS AND MOTOR DETAILS									390.87	860.03	ESTIMATED WEIGHT	TOTAL



INSTALLATION, OPERATION AND MAINTENANCE MANUAL POLARIS - SERIES TBM 200 LH (8") - TYPE PHO / PBO / PVO			29 of 29
DOCUMENT NBR. :	PED-010	REVISION:	1
		EFFECTIVE DATE:	08-24-2004

8.0 APPENDIX

- 8.1 **PUMP GENERAL ARRANGEMENT DRAWING, TBM 200 LH – PHO, PBO, PVO**
 - TBM 200 LH – 40 / 50 / 60 HP MOTOR
 - TBM 200 LH – 75 / 100 / 125 HP MOTOR
 - 8.1.1 **PUMP PERFORMANCE CURVE - TYPE PHO**
 - 8.1.2 **PUMP PERFORMANCE CURVE - TYPE PBO**
 - 8.1.3 **PUMP PERFORMANCE CURVE - TYPE PVO**
- 8.2 **RELIANCE ELECTRIC**
Application, Installation & Operation Manual
Duty Master® Submersible Motors
- 8.2 **MOISTURE DETECTION RELAY**
- 8.4 **IMPELLER INSTALLATION / BOLT TORQUE SPECIFICATIONS**

REVISIONS

REV	ECN	CHANGE DESCRIPTION	BY	APP	DATE
0		NEW RELEASE	UJB	UJB	8 AUG, 01
1		ADDED BOLT TORQUE SPECIFICATIONS	UJB	UJB	24 AUG, 04

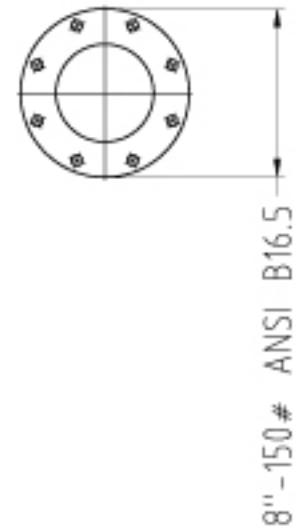
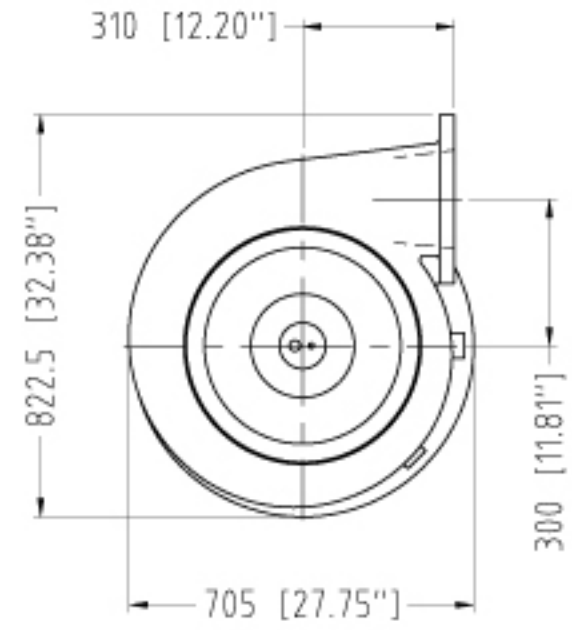
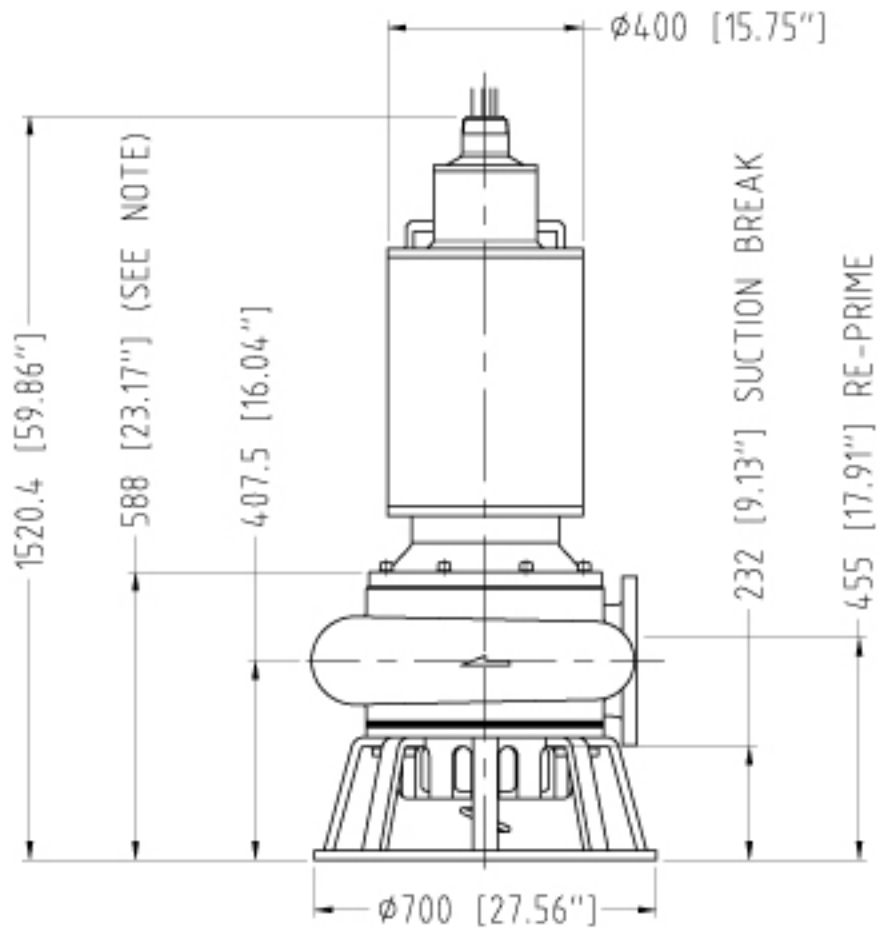

NOTE:
 MIN. SUBMERGENCE FOR MOTOR
 MODULES EQUIPPED WITH
 WATER JACKETS ONLY

GENERAL ARRANGEMENT, WEIGHTS	
TBM 200 LH-PHO, PBO, PVO (40 - 60 HP Motor)	
DRAWING NBR.: A0199	REV.: 0
EFFECTIVE DATE : 06-26-01	



PUMP MODEL	WEIGHT (lbs.)	WEIGHT (kg)
TBM 200 LH - PHO	2004	911
TBM 200 LH - PBO	2015	916
TBM 200 LH - PVO	2019.4	918

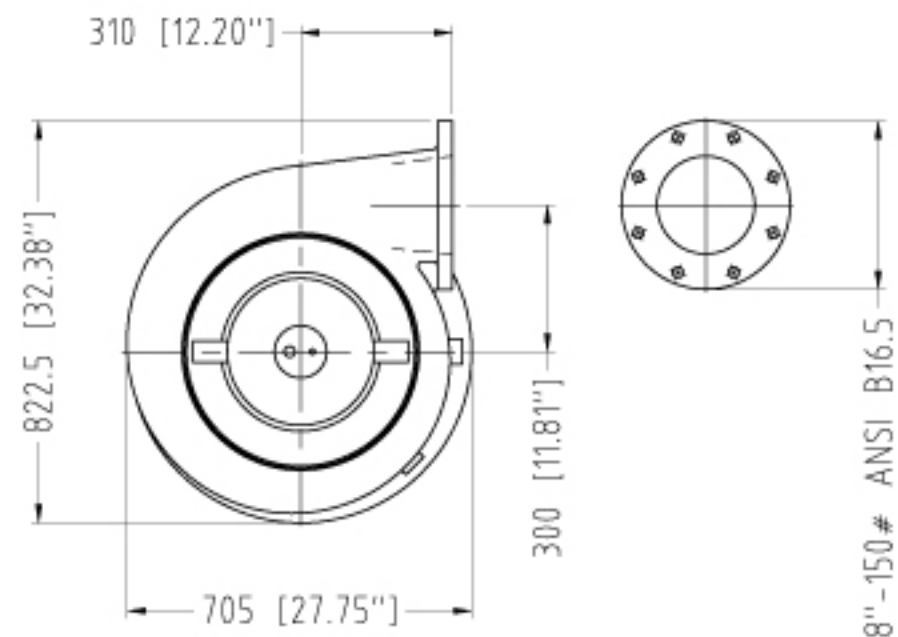
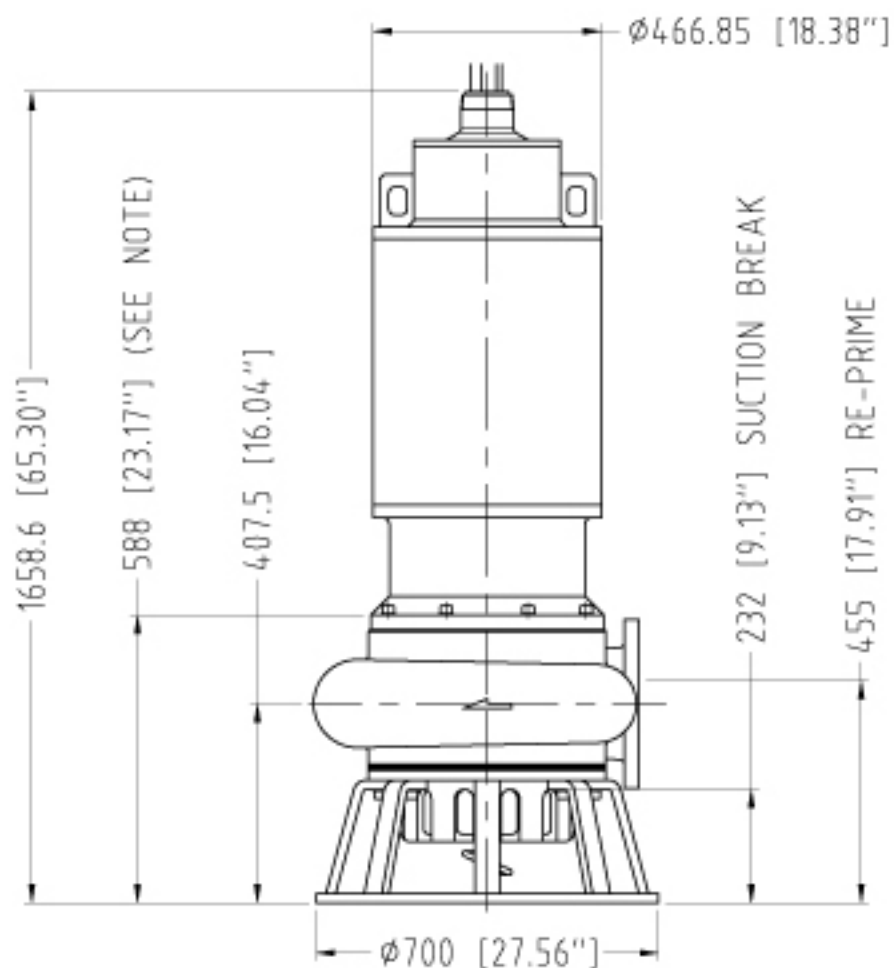

NOTE:
MIN. SUBMERGENCE FOR MOTOR
MODULES EQUIPPED WITH
WATER JACKETS ONLY

GENERAL ARRANGEMENT, WEIGHTS	
TBM 200 LH-PHO, PBO, PVO (75 - 125 HP Motor)	
DRAWING NBR.: A0198	REV.: 0
EFFECTIVE DATE : 06-12-01	

POLARIS
P U M P S
Pump'n Hard Iron

PUMP MODEL	WEIGHT (lbs.)	WEIGHT (kg)
TBM 200 LH - PHO	2354	1070
TBM 200 LH - PBO	2365	1075
TBM 200 LH - PVO	2369.4	1077

POLARIS

P U M P S

Pump'n Hard Iron

PUMP MODEL TBM 200 LH-PHO	CURVE NBR.: A0213	DISCHARGE ϕ (In) : 8	NUMBER OF VANES : 5
	REVISION : 2	IMPELLER ϕ (In) : 14.76	FRAME REF. : 320TY-360TYS
	TEST NBR.: TBM200LH-PHO-001	MAX. SOLIDS ϕ (In) : 1.58	FREQUENCY : 60 Hz
	EFFECTIVE DATE : 04-04-02	PERFORMANCE FOR <u>CLEAR WATER</u> @ 60°F/20°C AND 1.0 S.G. CORRECT FOR OTHER CONDITIONS AND/OR SOLIDS EFFECT	
	APPROVED BY : UJB		

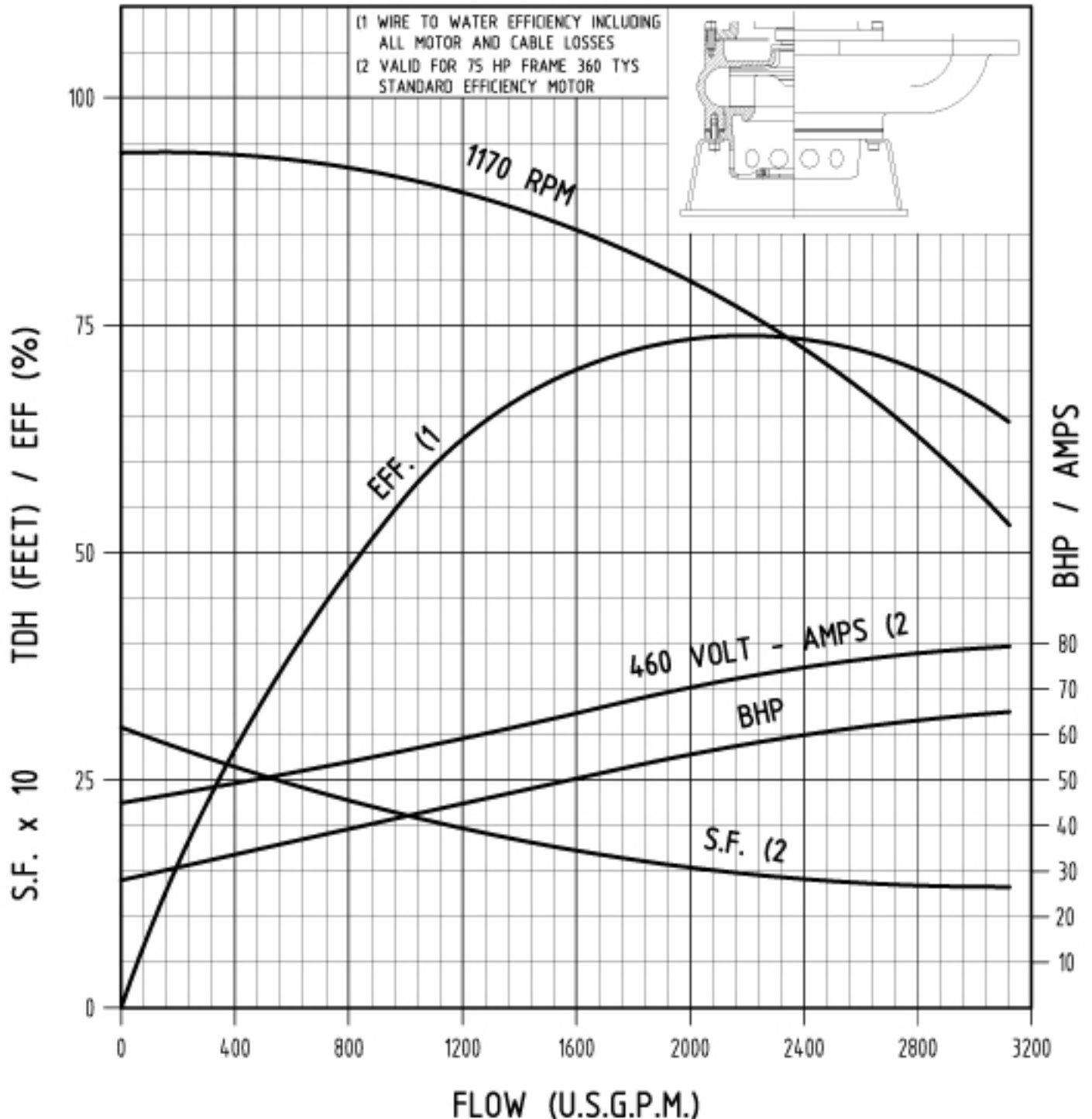

POLARIS

P U M P S

Pump'n Hard Iron

PUMP MODEL TBM 200 LH-P80	CURVE NBR.: A0214	DISCHARGE ϕ (In) : 8	NUMBER OF VANES : 5
	REVISION : 2	IMPELLER ϕ (In) : 14.76	FRAME REF. : 320TY-360TYS
	TEST NBR.: TBM200LH-P80-001	MAX. SOLIDS ϕ (In) : 1.58	FREQUENCY : 60 Hz
	EFFECTIVE DATE : 04-04-02	PERFORMANCE FOR <u>CLEAR WATER</u> @ 68°F/20°C AND 1.0 S.G. CORRECT FOR OTHER CONDITIONS AND/OR SOLIDS EFFECT	
	APPROVED BY : UJB		

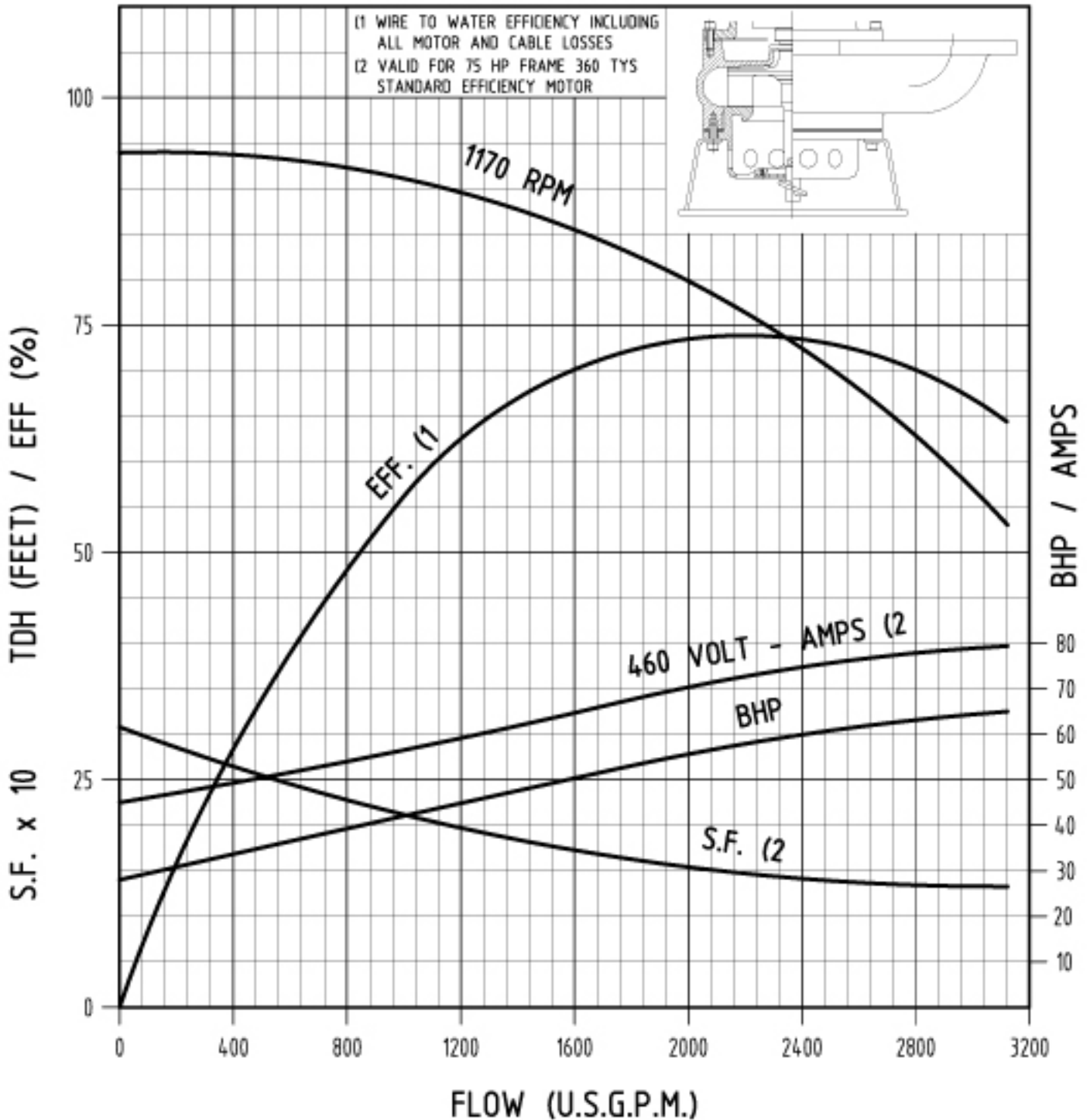

POLARIS

P U M P S

Pump'n Hard Iron

PUMP MODEL TBM 200 LH-PVO	CURVE NBR.: A0215	DISCHARGE ϕ (In) : 8	NUMBER OF VANES : 5
	REVISION : 2	IMPELLER ϕ (In) : 14.76	FRAME REF. : 320TY-360TYS
	TEST NBR.: TBM200LH-P80-001	MAX. SOLIDS ϕ (In) : 1.58	FREQUENCY : 60 Hz
	EFFECTIVE DATE : 04-04-02	PERFORMANCE FOR <u>CLEAR WATER</u> @ 68°F/20°C AND 1.0 S.G. CORRECT FOR OTHER CONDITIONS AND/OR SOLIDS EFFECT	
	APPROVED BY : UJB		

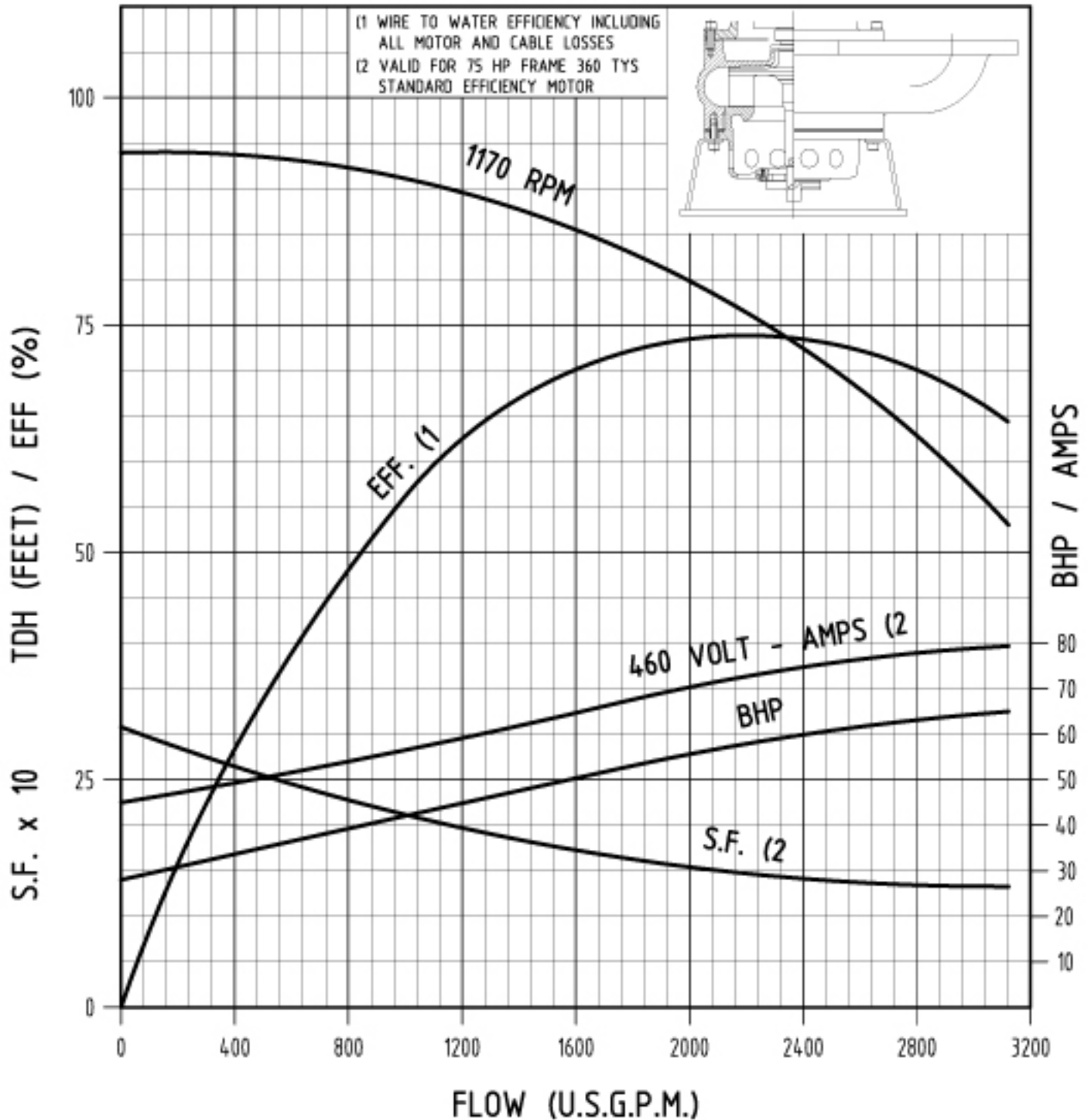

Application, Installation,
and Operation Of
Reliance®
Tandem Seal Single and
Polyphase Duty Master® A-C
Submersible Pump Motors

UL Listed for Class I
Groups C and D
in Water or Sewage
(Short Time Duty,
15 minutes in Air)

A-C MOTORS

*“Solutions
You Can
Trust”*

Instruction Manual B-3629-12
April, 1996

TABLE OF CONTENTS

	Page
RECEIVING AND HANDLING	1
INSTALLATION	2, 3
MAINTENANCE	4, 5
THERMAL PROTECTION SYSTEM	5, 6
MOISTURE DETECTION SYSTEM	6, 7
LEAD COLOR CODING	8
STANDARD REPLACEMENT SEAL CROSS REFERENCE	9
STANDARD REPLACEMENT "O" RING CROSS REFERENCE	9
STANDARD REPLACEMENT SNAP RING CROSS REFERENCE	10

 **IMPORTANT**

It is important that these instructions be studied by the personnel installing and operating this equipment. Read thoroughly before starting. Keep these instructions for future reference.

 **IMPORTANT**

The motors specified in this instruction book are U/L listed for application in Class I Groups C and D explosion-proof environments. All repairs, other than lead reconnects and outer seal replacement, shall be performed by an authorized Reliance service facility. Any other repairs performed by the customer or non-Reliance service facilities negates the U/L listing and motor warranty.

RECEIVING AND HANDLING

ACCEPTANCE

Thoroughly inspect this equipment before accepting shipment from the transportation company. If any of the goods called for in the bill of lading or express receipt are damaged or the quantity is short, do not accept them until the freight or express agent makes an appropriate notation on your freight bill or express receipt. If any concealed loss or damage is discovered later, notify your freight or express agent at once and request him to make an inspection. We will assist you in collecting claims for loss or damage in shipment; however, this willingness on our part does not remove the transportation company's responsibility in reimbursing you for collection of claims or replacement of material. Claims for loss or damage in shipment must not be deducted from the Reliance Electric invoice, nor should payment of the Reliance Electric invoice, be withheld awaiting adjustment of such claims, as the carrier guarantees safe delivery.

If considerable damage has been incurred and the situation is urgent, contact the nearest Reliance Electric Sales Office for assistance. Please keep a written record of all such communications.

UNPACKING

If facilities for the shelter of equipment are not available, repack motor and store shaft down until ready for use.

After unpacking and inspecting to see that all parts have been received in good condition, turn the motor shaft by hand to be sure that there are no obstructions to free rotation.

The motor should be checked for oil leaks after being removed from the crate. If positive indication of an oil leak is found around the shaft seal or drive end bracket, notify the nearest Reliance Electric Sales Office.

APPLICATION

All Reliance Submersible Pump Motors include thermal devices as standard. These devices are

required by UL on all motors 1 HP and larger listed Class I, Groups C and D. These devices are not recognized by UL for motors less than 1 HP but are included by Reliance for additional motor protection. **Motors less than 1 HP are supplied with a cautionary label and are suitable on applications where vapor or gas ignition temperatures exceed 280°C. These motors are listed for Class I, Group D only.**

Reliance Electric stocks common ratings through 100 HP continuous duty submerged in liquid, 15 minutes duty in air at nameplate horsepower. Designs through 250 HP and special continuous in air ratings are also available. (Continuous in Air Designs have a 1.0 Service Factor.)

Normally, there are four conditions during which a submersible sewage pump may be operated in gases or vapors.

1. When the wet well is being dewatered.
2. When the pump motor assembly is being lowered down the guiderails. The flow from the pump is needed during the installation process to insure that solids are cleared from the discharge flange area to insure proper seating.
3. When low-level cutoff controls fail.
4. When low-level sensors are positioned at the bottom of the pump assembly.

NOTE: Outer shaft seal must be in liquid when motor is operated, whether motor is submerged or in air.

Seals cannot be run in a dry environment without a significant reduction in seal life. If seal is to be run in a dry environment, a special design seal must be supplied. Standard seals applied in dry seal applications will not be covered by warranty.

CONTINUOUS OPERATION GASES OR VAPORS

It is the driven equipment manufacturer's responsibility to insure this motor product is properly applied.

Horsepower requirements are a function of pump design, impeller size & head and flow conditions. In gas operating time is a function of pit size, pump capacity, and flow conditions. Only the pump manufacturer can insure that the pump motor is properly applied for continuous in-gas or vapor operation. As with any motor product, it is essential that proper consideration be given to the load characteristics to insure the motor product will not be overloaded. Should such an overload occur, thermostats embedded in the windings will provide a signal to deenergize the motor. However, proper consideration of the application will prevent such an overload.

With reference to the diagram in figure 1, the following load conditions should be noted:

- A. Below level #1 (bottom of the pump) fluid is not pumped and no load is reflected to the motor.
- B. One pump should always be sized sufficiently large to draw the well down (even under maximum flow conditions). The maximum amount of time the motor will operate fully loaded and uncovered is the amount of time required to draw the well down from level #2 (top of the motor) to the bottom of the pump.
- C. Time described in B above should not be greater than 15 minutes if full motor nameplate horsepower is required for this operation. (See Application Instructions).

D. The above application notes do not make allowance for:

- (a) The heat exchanger effect of the attached pump. It is pumping a relatively cool fluid and will remove some heat.
- (b) The motor does not operate fully loaded *completely* in gas. It is fully loaded as the motor is being uncovered.
- (c) If the well is being drawn down from the top of the motor and maximum flow conditions exist, the influent flow will usually provide excellent cooling of the pump motor.

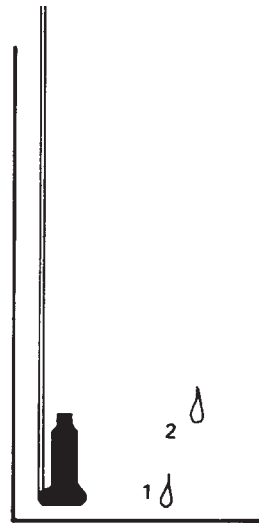

FIGURE 1

INSTALLATION

IMPORTANT

Read this manual thoroughly before installation.

- 1. The user must select a motor starter and over-current protection suitable for this motor and its application. Consult motor starter application data as well as the National Electric Code and/or other local codes.
- 2. Maximum submergence of motor is not to exceed 200 feet in depth and/or 200 P.S.I. at motor seal.

- 3. Thermal Protectors must be connected. Leads marked P1 and P2 (See Figure 2).
- 4. Moisture Sensing Probes must be connected. Leads marked W1 and W2. (See Figure 3).
- 5. Check your power supply against final nameplate connection voltage.

If required, the impeller should be heated slightly before pressing it on the shaft. *Under no circumstances should the impeller be driven on*

by pounding as this will damage the seal. When removing impeller warm slightly with a torch and pry impeller off evenly with either small pry bars or a wheel puller.

When the submersible pump motor leaves the factory it is ready for installation. No adjustment, venting or oil filling is required. For THREE PHASE motors the only connection to the motor lead cable is the power supply. For SINGLE PHASE motors the motor lead cable and power supply must be properly connected at the Control Box. Motor will operate successfully with frequency not more than 5% and voltage not more than 10% above or below nameplate data. Performance within this range will not necessarily be the same as the established performance at exact rated voltage and frequency.

All submersible pump motors will operate in either direction of rotation. To reverse direction of a THREE PHASE motor, interchange any two motor leads at the starter. To reverse direction of rotation of a SINGLE PHASE motor the proper connections must be made in the motor connection chamber; refer to the W/D's supplied in the motor connection chamber and Control Box.

Lifting eyes are supplied for purpose of installation and servicing. **(Do not use motor lead cables for lifting means.)** Normal care should be exercised to prevent mechanical damage to the seal, the frame and the insulated cable.

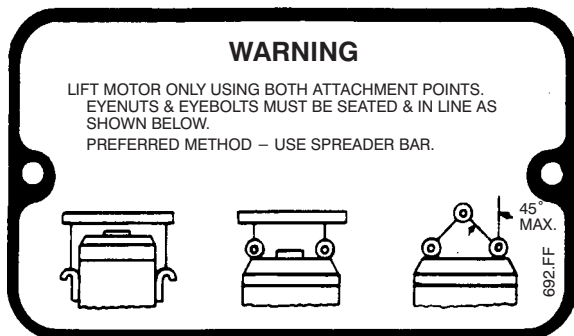

STARTING

CAUTION: Surface temperature of motor enclosure may reach temperatures which can cause discomfort or injury to personnel accidentally coming into contact with hot surfaces. (When installing, protection should be provided by user to protect against accidental contact with hot surface) .

On initial start up the motor and pump should be checked for proper rotation prior to final application.

The unit is designed to protect all power connections against moisture. All Reliance Submersible Pump Motors have a lead connection chamber. – THREE PHASE dual voltage motors have 9 motor leads and SINGLE PHASE dual voltage motors have 8 motor leads in this chamber. All Submersible Pump Motors have 2 thermal protector leads and 2 moisture sensing probe leads in this chamber.

Leads are tagged for easy identification. A connection diagram is provided in the lead chamber. Motors can be connected for either high or low voltages. (Some motor ratings are built as single voltage units and as such are not reconnectable).

The motor lead cable assembly for all Submersible Pump Motors has 3 marked power leads plus two ground leads, two thermal leads and two moisture sensing probe leads in standard cable lengths of 25 feet.

Leads are brought through an epoxy sealed connector providing a mechanically strong water tight seal. The cap and cable assembly are available from Reliance Electric as a replacement part assembly. When replacing the lead wire cap, care should be taken not to nick or damage the "O" ring seal. Replace any damaged or nicked "O" rings.

WHEN REPLACEMENT CABLE ASSEMBLY IS REQUIRED, ORDER FROM RELIANCE ELECTRIC CO. USING MOTOR IDENTIFICATION NUMBER.

MAINTENANCE

With proper application and installation of monitoring devices, periodic inspection of motor seals is not required. Should a malfunction occur the motor has been equipped with a moisture detection system and thermal protection which will provide advance warning of impending failure allowing the user to plan a maintenance program before failure occurs.

GENERAL NOTES: ALL PARTS

1. Reliance® Submersible Motors utilize an explosion-proof Class I, Groups C and D, tandem seal design, with an oil chamber separate from the winding area.
2. Wound Stators – Reliance Submersible Motors utilize a wound stator which has been pressed into the frame. The stator insulation system has been designed for the temperature and electrical rating involved. If the motor failure is analyzed to encompass a winding failure, return the motor to an authorized Reliance Electric Service Shop.
3. Encapsulated Lead Connector Assembly – The lead connector assembly has been especially encapsulated to insure integrity of the motor. The connector can be removed from the motor in order to reconnect leads. Should the lead connector assembly be damaged or the integrity of the encapsulation be in question, it is required that a replacement lead connector assembly be ordered from Reliance Electric Company.

 **WARNING**

MOTOR MAY CONTAIN GAS UNDER PRESSURE DUE TO HIGH TEMPERATURES FROM OPERATION WITHOUT BEING SUBMERGED. DISASSEMBLY MAY CAUSE BODILY INJURY. FOR ASSISTANCE CONTACT A RELIANCE OFFICE.

4. Hardware – All hardware is stainless steel and should be replaced with the same type.
5. If the Conduit Connection is used, a corrosion resistant conduit such as stainless steel is recommended.

6. When replacement cable assembly is required, order from Reliance Electric Industrial Co. using motor identification number.

MECHANICAL REPAIRS

U/L listed motors must be returned to an authorized Reliance Electric Service Facility for repairs other than to replace the outer seal. (See note on Table of Content page.)

To inspect the outer seal proceed as follows:

1. Remove outer snap ring (3), replace as needed.
2. Remove rotating outer seal (4), replace as needed.
3. Approved lubricating and insulating oil shall meet Reliance approved source sheet 4824-18-AF. Manufacturer's materials currently meeting this specification are as follows:

ITEM	MANUFACTURER	MANUFACTURER'S IDENTIFICATION OF MATERIAL
1	Sun Oil Company	Sun Fleet Regular SAE 10W
2	Standard Oil Co.	Sohio 62 SAE 10W
3	Shell Oil Company	Rotella 10 SAE 10W

MOTOR INSPECTION

After assembly, run motor in shaft down position for 30 seconds minimum to one minute maximum to allow seals to seat; then check for oil leakage. In some cases, a slight oil mist will appear around the seal. Wipe clean after test.

PAINTING AND SHIPPING

Before painting motor, cover exposed seal. Remove any paper, tape, etc., from seal area before crating motor. These motors can be shipped in shaft up or shaft down position. Care must be taken that exposed seal is not damaged during shipment. Carton must protect exposed seal from dirt, dust and damage.

ELECTRICAL REPAIRS

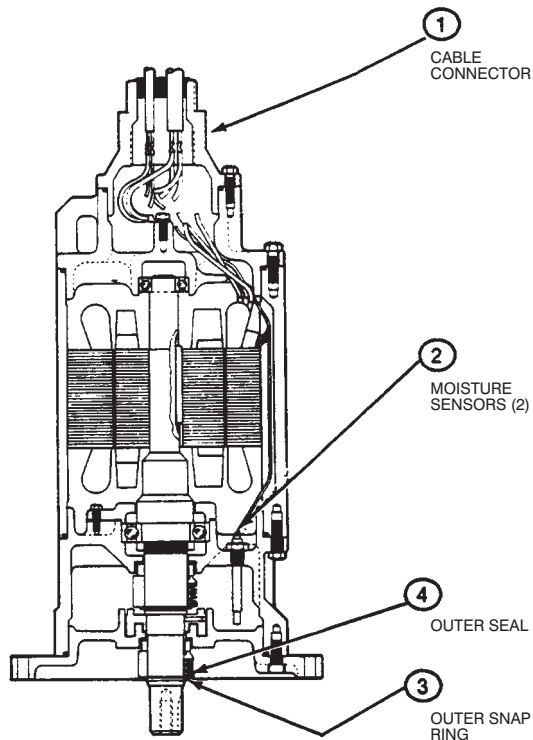

LEAD RECONNECT

The cable connector assembly may be removed to reconnect the leads without negating the U/L listing or the warranty.

 WARNING
MOTOR MAY CONTAIN GAS UNDER PRESSURE DUE TO HIGH TEMPERATURES FROM OPERATION WITHOUT BEING SUBMERGED. DISASSEMBLY MAY CAUSE BODILY INJURY. FOR ASSISTANCE CONTACT A RELIANCE OFFICE.

PROCEDURE

1. Loosen four bolts, securing lead cable connector (1), two complete turns.
2. Attempt to break the cable connector seal thus relieving gas pressure within the motor. If gas pressure is not relieved loosen the bolts another turn and try again. Continue this process until the pressure is relieved and/or the cap is removed. Be extremely careful until the cable connector assembly is removed.
3. Remove cable connector and reconnect to desired voltage as shown on connection diagram inside the cable connector.
4. Insulate connectors with 4824-13-AU heat shrinkable plastic. If the 4824-13-AU shrinkable plastic is not available, tape may be used, but it should be an oil resistant type. Enough wraps should be used to insure the buildup will be sufficient to prevent the connector from breaking through the insulation. The following procedure should be employed: Five layers of plastic electrical tape followed by two layers electrical grade woven adhesive tape, such as Mystik 7020 or 3M #27, for oil and abrasion resistance.
5. Place "O" ring over fit and coat fit with Chevron SRI grease (not excessive).
6. Place cable connector back on motor, install four bolts, and tighten.

THERMAL PROTECTION SYSTEM

THERMAL PROTECTION

 IMPORTANT
Reliance Submersible Pump Motors are equipped with thermal protection devices. Failure to properly connect or utilize this system voids motor warranty.

Thermostat leads marked P1 & P2 must be connected in series with the stop button of the 3-wire pilot circuit of the magnetic motor controller, so that the thermostat will open the circuit before dangerous temperatures are reached.

Thermostats are automatic reset for use in a normally closed circuit where the thermostat is connected in series with the holding coil of the magnetic starter. Thermostats provide "Over Temperature Protection 2" in accordance with NEMA MG 1-12.53. When the motor is so marked locked rotor protection is not provided by the winding over temperature protector. It is suggested that over current protection be used in the motor starter to insure locked rotor protection.

! WARNING
MOTOR CONTROLLER MAY HAVE AUTOMATIC OR MANUAL OVERLOAD RESET. DISCONNECT ALL POWER LEADS TO MOTOR WHEN PERFORMING ANY WORK ON MOTOR OR DRIVEN EQUIPMENT.
A MANUAL, MOMENTARY START SWITCH IS REQUIRED TO PREVENT AUTOMATIC RESTART OF MOTOR WHEN THERMOSTAT RESETS.

If current through the thermostat will exceed the values listed in Figure 2 an intermediate control circuit relay must be used to reduce the current or the thermostat will not work properly.

Alternating Current

Volts	Continuous Amperes	Inrush Amperes
110-120	3.0	30
220-240	1.5	15
440-480	0.75	7.5
550-600	0.6	6.0

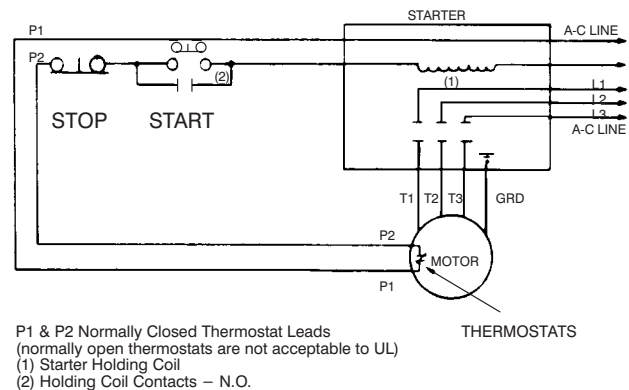

**FIGURE 2
TYPICAL THERMAL PROTECTOR
WIRING DIAGRAM**

MOISTURE DETECTION SYSTEM

MOISTURE SENSING PROBES

! IMPORTANT
Reliance Submersible Pump Motors are equipped with moisture detection devices. Failure to properly connect or utilize this system voids motor warranty.

Moisture sensing probes, leads marked W_1 , and W_2 , must be used in conjunction with an induction relay. This device will detect moisture entering the oil chamber due to failure of the outer seal and, when properly connected to a

warning device, will provide notification of needed maintenance. Integrity of system requires periodic test.

CONTROLS AND SIGNAL DEVICES

A control and signal device (not supplied by Reliance) must be installed at the job site to complete the moisture detection system.

Compatible controls are available from: Charles F. Warrick Co., Normandy Court, Royal Oak, Michigan 48073, (810) 549-4900.

CONTROL SELECTION AND ORDERING FOR CHARLES F. WARRICK CO. CONTROLS

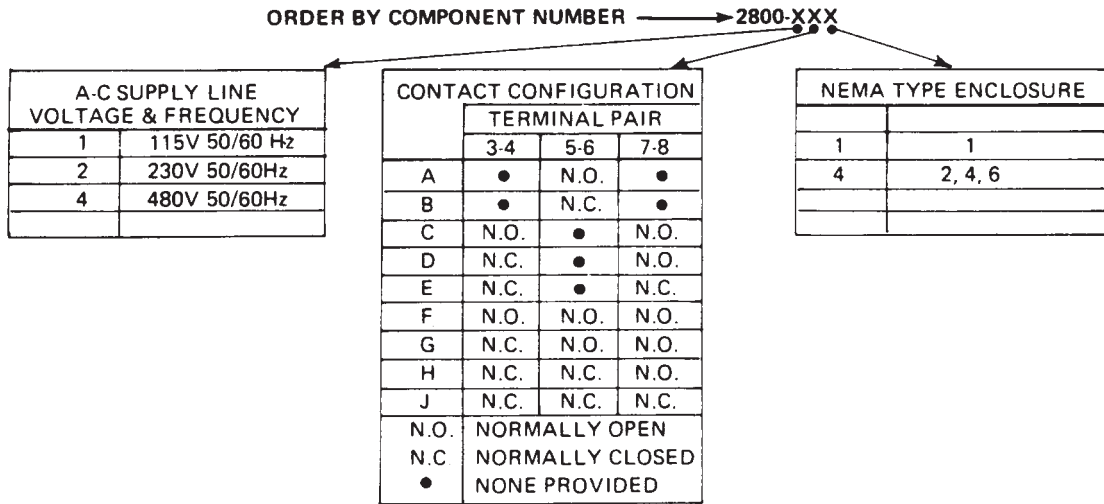

Line voltages are nominal values and may be anywhere from nominal minus 15% to nominal plus 10%.

TYPE 2800-XXX MOTOR MOISTURE DETECTOR CONTROL

INSTALLATION

All type 2800-XXX controls are identified by a specific component number which follows the format 2800-XXX where the X's are replaced by numbers and letters indicative of the A-C supply line voltage and frequency, contact configuration and enclosure. Each control has a data label on the right hand side of the terminal block. In addition, each enclosed control has another data label on the outside of the enclosure cover.

Mount the control on a vertical surface with the transformer on the left hand side and accomplish all indicated wiring. Terminals on the control are numbered and are in the same relative position as the terminals shown on the wiring diagram.

Terminal pair 1-2 must be continuously energized from an A-C supply line of electrical characteristics shown on the data label.

Contacts must be wired into the electrical load circuit(s) of the warning devices as required. Each contact used for load duty must be wired in series with the load and that series branch circuit connected across a power source compatible with the load.

Wiring must be provided from the moisture detector sensor probe leads of the RELIANCE ELECTRIC motor designated W1 and W2 to terminals 9 and 10 of the 2800-XXX control.

Control leads should not be installed in the same conduit as power leads. Induced voltage can cause false moisture signals.

CONTACT OPERATION

Normally open load contacts close and normally closed load contacts open when the sensor probes detect the influx of moisture within the motor.

TEST PROCEDURE

A normally closed pushbutton and neon indicating lamp are provided as means of checking the moisture sensing components.

When the pushbutton is depressed, the indicating lamp will be illuminated to indicate (A) power is supplied to the control, (B) the control is operative, and (C) wiring to the moisture sensing probes in the motor is intact. This procedure should be performed periodically to confirm integrity of circuit.

SIGNAL DEVICES

The signal device may be audible (bell, buzzer, horn or siren) or visible (incandescent or neon lamp) or both – a signal device of your choice may be obtained from your local electrical supply house.

SYSTEM OPERATION

It is recommended that upon indication (by warning light, etc.,) of outer seal failure that the motor be removed from the installation and the oil and outer seal be replaced as soon as possible.

If reconditioning is not performed within a 30 day period it is recommended that the inner seal be thoroughly inspected and replaced if required.

When ordering parts or reporting trouble give Sales Office complete Nameplate Data.

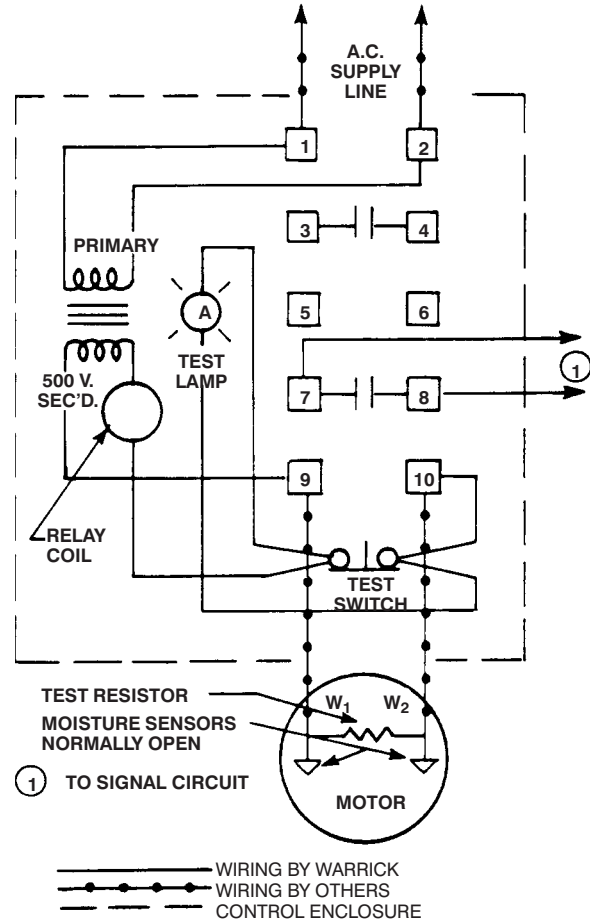
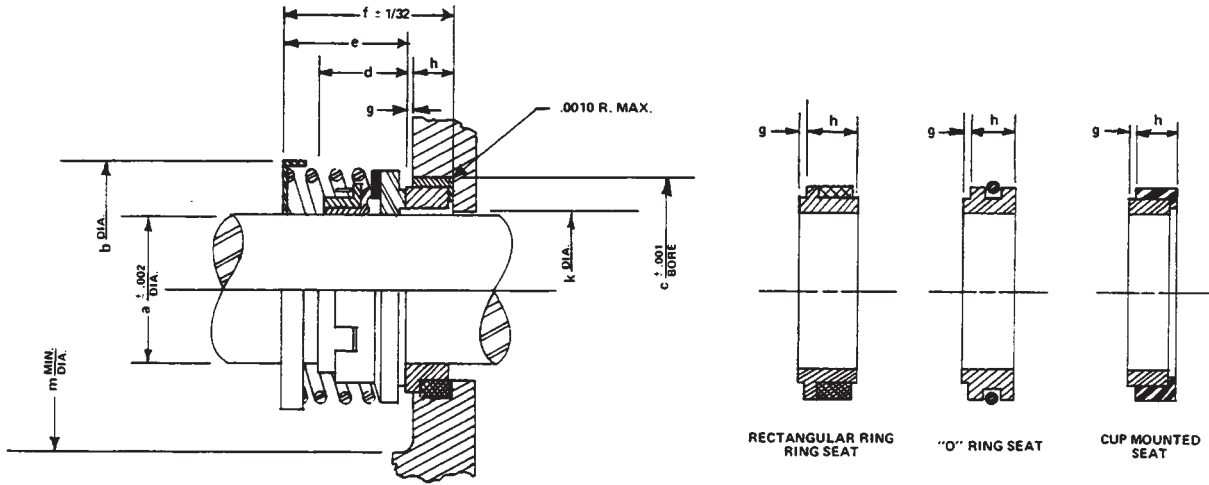

FIGURE 3
MOISTURE SENSING CIRCUIT
TYPICAL WIRING DIAGRAM

LEAD COLOR CODING

		BLACK LEAD	WHITE LEAD	RED LEAD	ORANGE LEAD	GREEN LEAD
Power Cable	Polyphase	T ₁	T ₂	T ₃	—	Ground
	Single Phase	T ₁	T ₄	T _A	—	Ground
Control Cable	All	P ₁	P ₂	W ₁	W ₂	Ground

STANDARD REPLACEMENT SEAL CROSS REFERENCE



PURCHASING SPECIFICATIONS													
Part No. 64262-	a	Crane Type Seal	Type Seat	Spring Code No.	b	c	d	e	f	g	h	k	m
12-A	1.250	T-21	Cup Ceramic	BP1C1	1-15/16	1.875	47/64	1-1/16	1-1/2	1/16	3/8	1-7/16	2-3/16
12-B	1.500	T-21	Cup Ceramic	BP1C1	2-3/16	2.125	47/64	1-1/8	1-9/16	1/16	3/8	1-11/16	2-3/16
12-C	1.750	T-21	Cup Ceramic	BP1C1	2-5/8	2.500	49/64	1-3/8	1-7/8	1/16	7/16	1-15/16	2-7/8
12-D	2.000	T-21	Cup Ceramic	BP1C1	2-7/8	2.750	49/64	1-1/2	2	1/16	7/16	2-3/16	3-3/16
12-E	2.250	T-21	Cup Ceramic	BP1C1	3-1/8	3.125	49/64	1-11/16	2-1/4	1/16	1/2	3-7/16	3-7/16
12-G	3.00	T-21	Cup Ceramic	BP1C1	4.00	4.125	2.687	2.062	2.687	0.06	0.56	3.19	4.50
18-F	2.75	T-21	Cup Ceramic	BP1C1	3.75	3.500	0.796	1.125	1.75	0.03	0.595	2.94	4.12
18-G	3.00	T-21	Cup Ceramic	BP1C1	4.00	3.875	0.796	1.125	1.75	0.06	0.56	3.19	4.50
18-N	2.75	T-21	Cup Ceramic	BP1C1	3.75	3.50	0.796	1.125	1.75	0.06	0.56	2.94	4.12
8-J	3.25	T-21	Cup Ceramic	BP1C1	4.84	4.125	2.187	2.187	2.968	0.06	0.69	3.44	4.88

STANDARD REPLACEMENT "O" RING CROSS REFERENCE

Part No. 421900	I.D.	Nominal W.	UL Listed Material	Approved Suppliers and Compound Number	
60-FU	3.750	0.139	BUNA N	National Seal	No. B-46A
72-FU	4.500	0.125	BUNA N	Parker Seal	N-219-7
94-FU	5.875	0.125	BUNA N	Precision Rubber	No. 1197
100-FU	6.250	0.125	BUNA N	Crane Packing	No. 2561
124-FU	7.750	0.125	BUNA N		
144-FU	9.000	0.125	BUNA N		
168-FU	10.500	0.125	BUNA N		
192-FU	12.000	0.125	BUNA N		
208-FU	13.000	0.140	BUNA N		
240-FU	15.000	0.140	BUNA N		

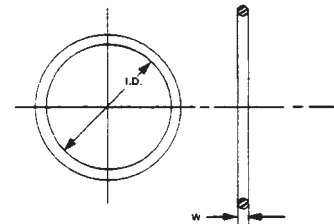

TO BE USED AT 9-1/2 I.D.
@ 3/32 NOM. THICKNESS

STANDARD REPLACEMENT SNAP RING CROSS REFERENCE

Part No. 47174-5-	a	T	Shaft Size	Waldes Catalog Number	Remarks
A	1.156 + .010 - .015	.050 ± .002	1-1/4	5108-125-H	#420 Stainless
B	1.387 + .010 - .015	.050 ± .002	1-1/2	5108-150-H	#420 Stainless
C	1.637 + .013 - .020	.062 ± .003	1-3/4	5108-177-H	#420 Stainless
D	1.850 + .013 - .020	.062 ± .003	2	5108-200-H	#420 Stainless
E	2.081 + .015 - .025	.078 ± .003	2-1/4	5108-225-H	#420 Stainless
H	2.543 + .015 - .025	.093 ± .003	2-3/4	5100-275-H	#420 Stainless
F	2.775 + .020 - .030	.093 ± .003	3	5100-300-H	#420 Stainless
G	3.006 + .020 - .030	.093 ± .003	3-1/4	5100-325-H	#420 Stainless

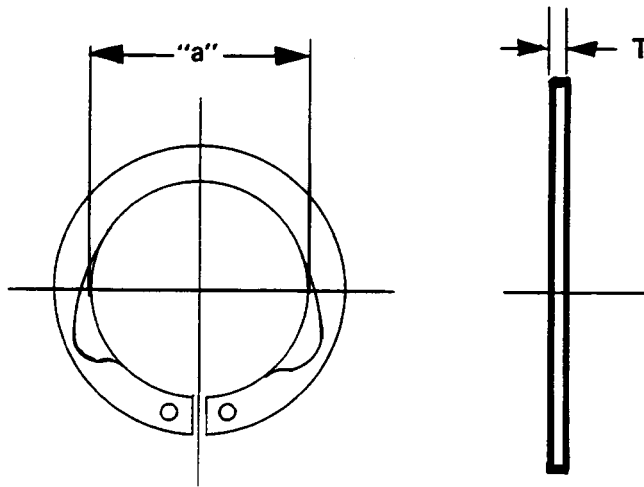

NOTE: *Outer shaft seal must be in liquid when motor is operated, whether motor is submerged or in air.*

Seals cannot be run in a dry environment without a significant reduction in seal life.

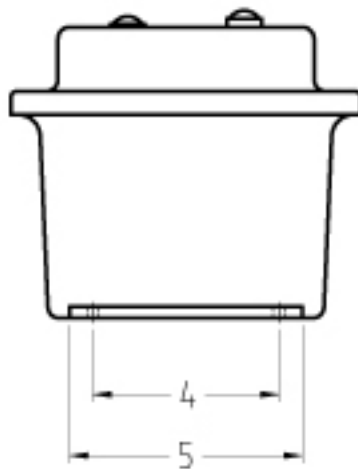
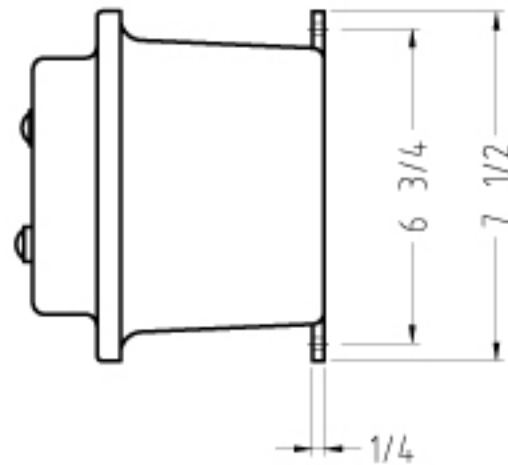
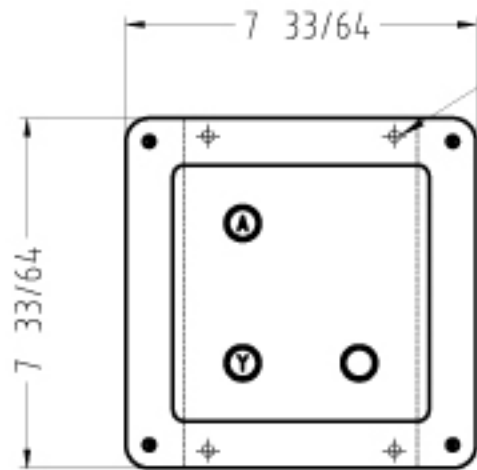

SPECIFY SUPPLY LINE VOLTAGE

TYPE 2810 CONTROL RELAYS



- 1 - 115 VAC
- 2 - 230 VAC
- 4 - 460 VAC
- 5 - 575 VAC

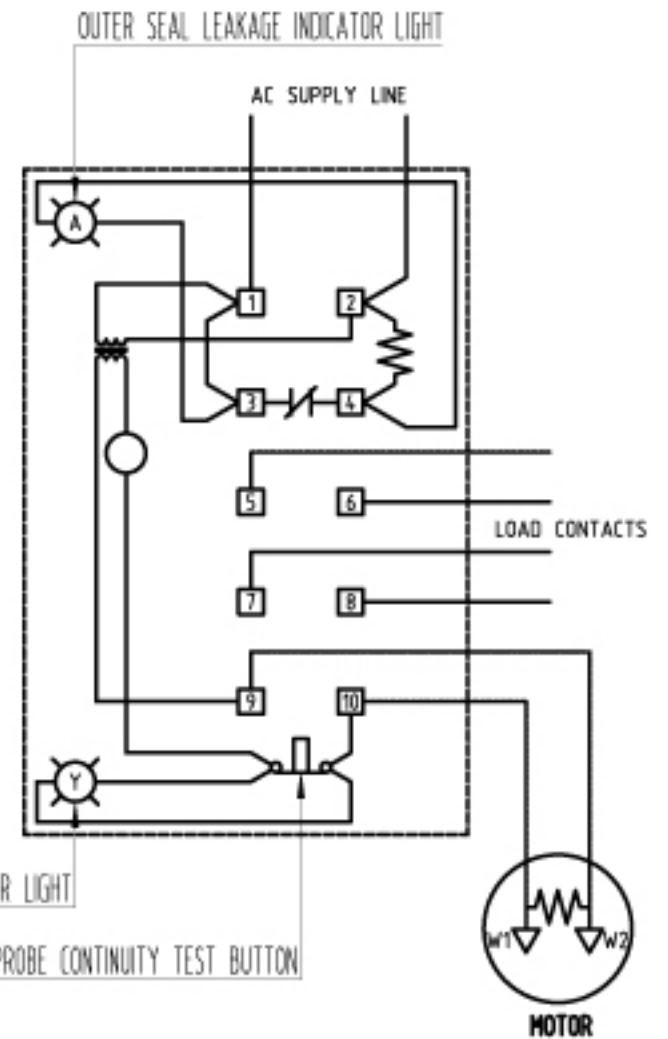

MOISTURE DETECTION CONTROL

NEMA TYPE 4 ENCLOSURE, WEATHER PROOF

DRAWING NBR.: A0181

REV.: 3

EFFECTIVE DATE : 08-28-01

POLARIS

P U M P S

Pump'n Hard Iron

ENGINEERING STANDARD PROCEDURE IMPELLER INSTALLATION – TECH BULLETIN				1 of 2	
DOCUMENT NBR. :	PED-016	REVISION:	1	EFFECTIVE DATE:	09-26-2003

1.0 SCOPE: The purpose of this Engineering Standard Document is to define the procedure to be followed in installing the Impeller and Impeller Lock Screw.

2.0 METHOD:



2.1 – Impeller Installation

Clean all parts prior to impeller installation.
Apply “Never Seize” or similar to Impeller bore, Shaft and Key.
Install Impeller onto Shaft. Using a grease remover or solvent, remove all grease, oil or preservative from the shaft-end internal threads and dry.



2.2 – Impeller Blocking

Position an Open End or Box / Open End Wrench Using one of the Strainer Bolts as shown. Place a piece of Wood between the Impeller and Wrench.

Note: Reverse Wrench Location to opposite side for Impeller removal.

0		NEW	UJB		08-15-02
1		ADDED250LH	UJB		09-26-03
REV	ECN	CHANGE DESCRIPTION	BY	APPV'D	DATE

ENGINEERING STANDARD PROCEDURE IMPELLER INSTALLATION – TECH BULLETIN				2 of 2	
DOCUMENT NBR. :	PED-016	REVISION:	1	EFFECTIVE DATE:	09-26-2003



2.3 – Impeller Cap Installation

Remove all oil or grease from Impeller Screw. Install O-rings onto Impeller Screw and Impeller Cap (Model PHO) or Shaft Adapter (Models PBO, PVO). Insert Impeller Screw and apply Thread Locker to the Impeller Screw and shaft-end internal threads.

Use **Devcon® SuperLock 2271** High Strength Stud Lock Grade or equivalent.



2.4 – Lock Screw Installation

Align and insert the Impeller Cap or Shaft Adapter into the Impeller Counter Bore. Insert the Lock Screw into Motor Shaft and tighten using a Torque Wrench or Allen Wrench with suitable extension.

See Table below for required Torque.

2.5 - Impeller Lock Screw Torque Requirements

TBM 50LH – 100LH	(1/2"-13 UNC)	55 ft/lbs (75 Nm)
TBM 150LH	(5/8"-11 UNC)	110 ft/lbs (150 Nm)
TBM 200LH	(3/4"-10 UNC)	200 ft/lbs (275 Nm)
TBM 250LH	(3/4"-10 UNC)	200 ft/lbs (275 Nm)
TBM 75MH	(5/8"-11 UNC)	110 ft/lbs (150 Nm)
TBM 100MH	(5/8"-11 UNC)	110 ft/lbs (150 Nm)
TBM 150MH	(3/4"-10 UNC)	200 ft/lbs (275 Nm)
TBM 200MH	(3/4"-10 UNC)	200 ft/lbs (275 Nm)

0		NEW	UJB		08-15-02
1		ADDED250LH	UJB		09-26-03
REV	ECN	CHANGE DESCRIPTION	BY	APPV'D	DATE



Pump'n Hard Iron

ENGINEERING STANDARD PROCEDURE IMPELLER INSTALLATION – TECH BULLETIN				1 of 1
DOCUMENT NBR. :	PED-017	REVISION:	0	EFFECTIVE DATE: 09-16-2003

1.0 SCOPE:

Assembly Pre-Load / Bolt Torque requirements for Metric Fasteners of Grades A2-70 (304L) A4-70 (316L) and 8.8, for Sizes M4 to M20.

2.0 METHOD:

ASSEMBLY TORQUE / ASSEMBLY PRE-LOAD					
SIZE	CLASS	TIGHTENING TORQUE		ASSEMBLY PRE-LOAD	
		Nm	lb/ft [lb/in]	kN	lbf
M4	A2-70, A4-70, 8.8	2.20	1.622 [19.46]	2.73	612.23
M5		4.20	3.097 [37.16]	4.47	1002.44
M6		7.40	5.45 [65.40]	6.31	1415.08
M8		17.80	13.12	11.60	2601.42
M10		36.00	26.54	18.40	4126.40
M12		62.00	45.72	26.90	6032.62
M16		150.00	110.62	50.90	11414.88
M20		303.00	223.45	82.00	18389.40

ABOVE TORQUE / PRE-LOAD VALUES ARE BASED ON A COEFFICIENT OF FRICTION OF 0.14 (Anti-seize Lubricant)

0		NEW	UJB		08-15-02
1		ADDED250LH	UJB		09-26-03
REV	ECN	CHANGE DESCRIPTION	BY	APPV'D	DATE